

NYC Department of Education
Building Condition Assessment Survey 2023 - 2024

Architectural Inspection

K874

Asset: I.S. 340 (OLD 249 AX) - BROOKLYN, 227 STERLING PLACE, New York, 11238

Inspection Id	Inspection Type	Time In	Last Edited
SA : K874	Architectural - Senior	2023-12-11 7:29 AM	2024-01-02 6:52 PM
AA : K874	Architectural - Associate	2023-12-11 8:43 AM	2024-01-05 4:52 PM

Asset Data

Question	Answer
Was the building fully accessible for inspection	No
Inspection Access Comment	Coping, Parapets, Roofing (Roofs 2 and 3, Roofing Drains ((No access); Library Room 105 (storage)
Building Square Footage	31,000
Comments on the Area (for Athletic Field, Playing Surfaces, Leased Spaces)	None
Comments on the Stories (Floors) plus Basements	2+B+Attic
Comments on the Number of Classrooms	18
Comments on the Year Built	1867
Student Population	140
Staff Population	35
Weather	Fair
Principal(s) Information	
Principal Name	Tamara Johnson
Organization	I.S. 340 - Brooklyn
Did you meet with this Principal?	Yes
Did this Principal provide feedback?	Yes
Summary of Principal's Feedback	The Principal's comment is as follows: 1. The electrical outlets in the classrooms are insufficient.
Custodian	Najeeb Kaid
Fireman	Scott Allison (Cleaner)
Facade Photo	



Corner of Sterling Place and Vanderbilt Avenue - Northwest View

**NYC Department of Education
Building Condition Assessment Survey 2023 - 2024**

Architectural Inspection

K874

Main Entrance Photo



Facade A - Sterling Place

Roof Photo



Roof 1 - South View

Have any Systems/Major Building Components been upgraded?

Yes

Systems: Windows Caulking, Chimney repairs and Leaders replaced.

Year: 2018

Systems: Foundation Waterproofing.

Year: 2013

Systems: Partial Leaders and Gutters repaired.

Year: 2012

Systems: Roofing and Flashing replacement.

Year: 2003

Systems: Windows - replacement

Year: 1995

Have there been any Building Additions?

Yes

Comments on Building Additions

1884 (+14,000 S.F.)

Tandem Schools?

No

Leased Space?

No

Priority Condition

Priority Condition Exist Last Year?	Priority Category	Condition Description	Component Affected	Location Description	Person(s) Notified	Person(s) Title	PhotoImage
-------------------------------------	-------------------	-----------------------	--------------------	----------------------	--------------------	-----------------	------------

NYC Department of Education
Building Condition Assessment Survey 2023 - 2024

Architectural Inspection

K874

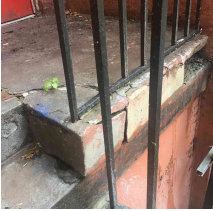
No	Tripping Hazard	Severely damaged concrete floor is a potential tripping hazard.	INTERIOR KITCHEN Floor Finish	Near kitchen exit	Scott Allison	Cleaner	
Yes	Tripping Hazard	Deteriorated stair is a potential safety hazard.	EXTERIOR STAIRS/RAMP S: EXTERIOR STAIRS/RAMP S	Southwest Exit Stair to West Courtyard	Najeeb Kaid	Custodian	

Structural Engineer Required

Structural Condition Type	Condition Description	Component Affected	Location Description	Person(s) Notified	Person(s) Title	PhotoImage
No condition recorded						

Programmatic Accessibility

Programmatic Accessibility Status Question	Response
Is the primary or secondary entrance on an accessible route?	No

Physical Breakdown Structure	Exists	Required	Complies	Deficiency	Assistive Listening System	Fire Alarm Strobe
------------------------------	--------	----------	----------	------------	----------------------------	-------------------

PROGRAMMATIC ACCESSIBILITY

Exterior Routes

Exterior Entrances & Exits			Yes			
Exterior H/C Lifts	No	No				
Exterior Ramps and Railings	No	Yes				

Interior Routes

Corridor and Lobby H/C Lifts	No	No				
Interior Corridor Doors and Hardware	No	No				
Interior Corridors and Lobbies			Yes			
Interior Elevators	No					
Interior Lobby Doors and Hardware			Yes			
Interior Ramps	No					

Rooms & Spaces

Art Rooms		No				
Auditorium	2nd Floor	Yes	No	Not on Accessible Route	No	No
Cafeteria	Basement	Yes	No	Not on Accessible Route	No	No
Classrooms	None on Accessible Route	Yes	No	Not on Accessible Route		
Computer Rooms		No				
Gymnasium		No				
Library	Room 105	Yes	No	Not on Accessible Route		
Main Office	Room 103	Yes	No	Not on Accessible Route		
Multi-purpose Room	Basement	Yes	No	Not on Accessible Route	No	No
Nurse's Room	Room 110B	Yes	No	Not on Accessible Route		
Pool		No				

NYC Department of Education
Building Condition Assessment Survey 2023 - 2024

Architectural Inspection

K874

Physical Breakdown Structure	Exists	Required	Complies	Deficiency	Assistive Listening System	Fire Alarm Strobe
Rooms & Spaces						
Science Lab	Room 214	Yes	No	Not on Accessible Route		
Toilet Rooms (Boys)	None on Accessible Route	Yes	No	Not on Accessible Route		
Toilet Rooms (Girls)	None on Accessible Route	Yes	No	Not on Accessible Route		
Toilet Rooms (Staff)	None on Accessible Route	Yes	No	Not on Accessible Route		

Building Template

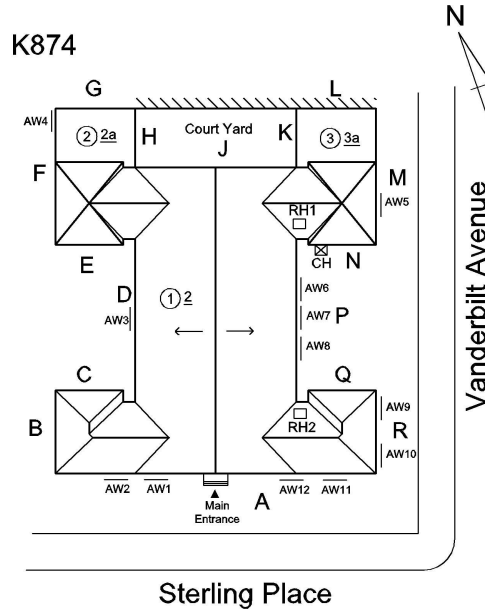

Inspection

Question	Response
Architectural	
EXTERIOR	Inspected
AREAWAY	Inspected
Instance on AW1 - AW12	Inspected
Instance Condition	3 - Fair
Instance Quantity	12
Instance Quantity Uom	EACH
Deficiency	AREAWAY GRATINGS: MAJOR RUSTING / OR BROKEN
Roof Plan reference	
Deficiency Quantity	20
Quantity Uom	S.F.
Potential Action	REPLACE

**NYC Department of Education
Building Condition Assessment Survey 2023 - 2024**

Architectural Inspection

K874

Question

Response

EXTERIOR

AREAWAY

Urgency of Action
Purpose of Action
Deficiency Photo1

PRIORITY 4
LEVEL 2



AW9

Violations

No violations recorded.

Deficiency

AREAWAY WALLS: DETERIORATED COPING STONE

Roof Plan reference

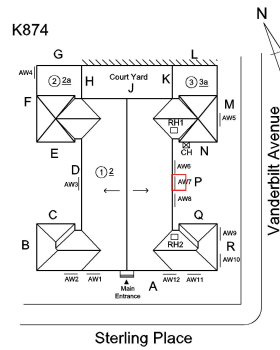

Deficiency Quantity
Quantity Uom
Potential Action
Urgency of Action
Purpose of Action
Deficiency Photo1

20
S.F.
REPLACE
PRIORITY 4
LEVEL 4

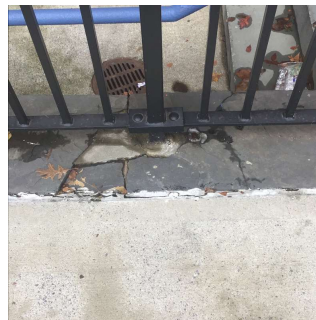

AW7

Violations

35663265K

Deficiency

AREAWAY WALLS: CRACKS AND SPALLING

**NYC Department of Education
Building Condition Assessment Survey 2023 - 2024**

Architectural Inspection

K874

Question

Response

EXTERIOR

AREAWAY

Roof Plan reference

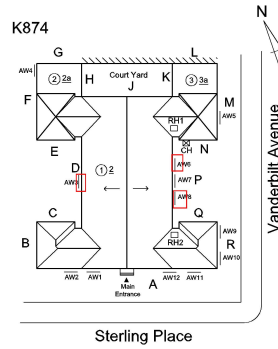

Deficiency Quantity
Quantity Uom
Potential Action
Urgency of Action
Purpose of Action
Deficiency Photo1

40
S.F.
REPAIR
PRIORITY 3
LEVEL 2



AW8

Violations

No violations recorded.

Deficiency

AREAWAY WALLS: DETERIORATED COPING STONE

Roof Plan reference

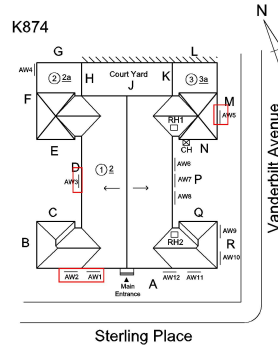

Deficiency Quantity
Quantity Uom
Potential Action
Urgency of Action
Purpose of Action

40
S.F.
REPAIR
PRIORITY 3
LEVEL 2

**NYC Department of Education
Building Condition Assessment Survey 2023 - 2024**

Architectural Inspection

K874

Question

Response

EXTERIOR

AREAWAY

Deficiency Photo1



AW1

Violations

No violations recorded.

Deficiency

AREAWAY WALLS: DETERIORATED JOINTS AT COPING STONES

Roof Plan reference

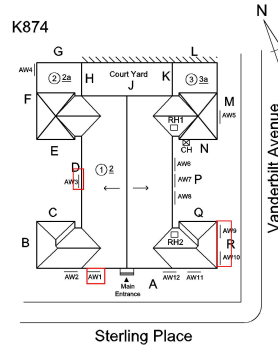

Deficiency Quantity

25

Quantity Uom

L.F.

Potential Action

MAINTENANCE

Urgency of Action

PRIORITY 3

Purpose of Action

LEVEL 2

Deficiency Photo1



AW1

Violations

No violations recorded.

Deficiency

AREAWAY WALLS: DETERIORATED COPING STONE

**NYC Department of Education
Building Condition Assessment Survey 2023 - 2024**

Architectural Inspection

K874

Question

Response

EXTERIOR

AREAWAY

Roof Plan reference

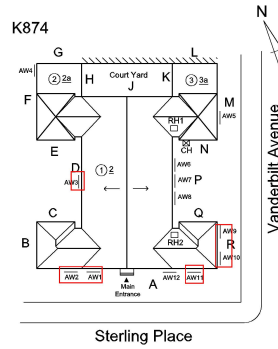

Deficiency Quantity
Quantity Uom
Potential Action
Urgency of Action
Purpose of Action
Deficiency Photo1

60
S.F.
REPLACE
PRIORITY 4
LEVEL 2

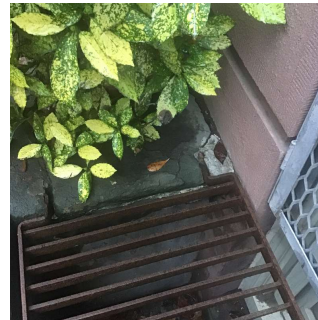

AW1
No violations recorded.

Violations

AWNINGS AND CANOPIES

Does not Exist

CHIMNEY

Inspected

Material Type(s)

Masonry

Condition

2 - Between Good and Fair

Deficiency

No deficiencies recorded

COPING

Inaccessible

CORNICE

Inspected

Condition

3 - Fair

Deficiency

WOOD: DETERIORATED

Roof Plan reference

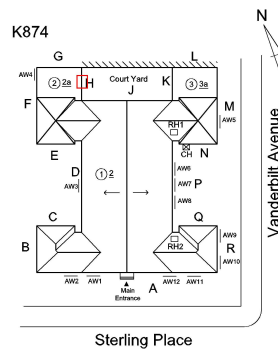

Deficiency Quantity
Quantity Uom
Potential Action
Urgency of Action

10
S.F.
REPLACE
PRIORITY 4

**NYC Department of Education
Building Condition Assessment Survey 2023 - 2024**

Architectural Inspection

K874

Question	Response
----------	----------

EXTERIOR

CORNICE

Purpose of Action
Deficiency Photo1

LEVEL 2



Facade H

No violations recorded.

Violations

DOORS

Inspected

DOORS AND FRAMES

Inspected

Condition

5 - Poor

Deficiency

METAL CLAD: DETERIORATED DOOR - MAJOR DETERIORATION

Roof Plan reference

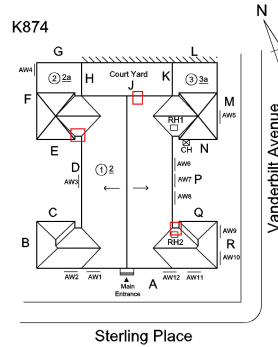

Deficiency Quantity
Quantity Uom
Potential Action
Urgency of Action
Purpose of Action
Deficiency Photo1

3
EACH
REPLACE
PRIORITY 4
LEVEL 2



Facade J - Kitchen Exit

No violations recorded.

Violations

Deficiency

METAL: DETERIORATED DOOR AND FRAME - MAJOR DETERIORATION

**NYC Department of Education
Building Condition Assessment Survey 2023 - 2024**

Architectural Inspection

K874

Question

Response

EXTERIOR

DOORS

DOORS AND FRAMES

Roof Plan reference

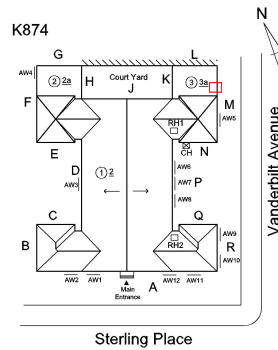

Deficiency Quantity
Quantity Uom
Potential Action
Urgency of Action
Purpose of Action
Deficiency Photo1

1
EACH
REPLACE
PRIORITY 4
LEVEL 4



Facade M - Boiler Room Exit at AW5
35636275K

Violations

DOOR HARDWARE

Inspected

Condition

3 - Fair

Deficiency

No deficiencies recorded

LINTELS

Inspected

Condition

2 - Between Good and Fair

Deficiency

No deficiencies recorded

TRANSOM/SIDE LIGHT

Inspected

Condition

3 - Fair

Deficiency

WOOD: EXCESSIVELY WEATHERED

Roof Plan reference

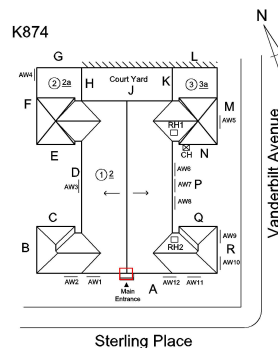



Deficiency Quantity
Quantity Uom
Potential Action

20
S.F.
REPAIR

**NYC Department of Education
Building Condition Assessment Survey 2023 - 2024**

Architectural Inspection

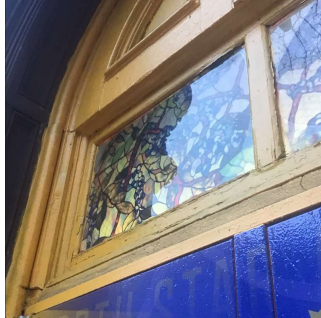
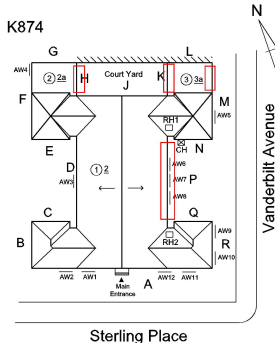
K874

Question	Response
EXTERIOR	
DOORS	
TRANSOM/SIDE LIGHT	
Urgency of Action	PRIORITY 3
Purpose of Action	LEVEL 2
Deficiency Photo1	
	Facade A - Main Entrance
Violations	No violations recorded.
EXTERIOR WALLS	
Material Type(s)	Inspected Masonry
Replacement Quantity	18,000
Replacement Uom	S.F.
Instance on All Facades	Inspected
Instance Condition	4 - Between Fair and Poor
Instance Quantity	18,000
Instance Quantity Uom	S.F.
Deficiency	BRICK: EFFLORESCENCE
Roof Plan reference	
Elevation	
Deficiency Quantity	500
Quantity Uom	S.F.
Potential Action	MAINTENANCE
Urgency of Action	PRIORITY 1
Purpose of Action	LEVEL 1

**NYC Department of Education
Building Condition Assessment Survey 2023 - 2024**

Architectural Inspection

K874

Question

Response

EXTERIOR

EXTERIOR WALLS

Deficiency Photo1



Facade P

No violations recorded.

Violations

Deficiency

STONE: CHIPPED/SPALLED/BROKEN PIECES - MAJOR

Roof Plan reference

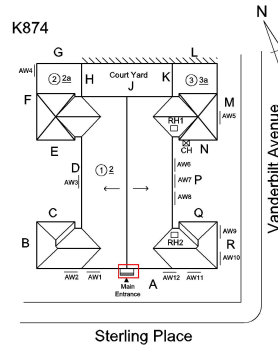

Elevation



Deficiency Quantity

40

Quantity Uom

S.F.

Potential Action

REPLACE

Urgency of Action

PRIORITY 4

Purpose of Action

LEVEL 4

Deficiency Photo1



Facade A

35663265K

Violations

Deficiency

BRICK: DETERIORATED JOINTS

**NYC Department of Education
Building Condition Assessment Survey 2023 - 2024**

Architectural Inspection

K874

Question

Response

EXTERIOR

EXTERIOR WALLS

Roof Plan reference

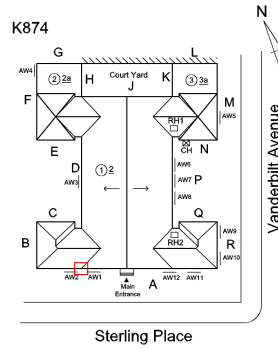

Elevation



Deficiency Quantity

20

Quantity Uom

S.F.

Potential Action

REPOINT

Urgency of Action

PRIORITY 4

Purpose of Action

LEVEL 4

Deficiency Photo1



Facade A

35663265K

Violations

BRICK: MAJOR / THRU CRACKS

Deficiency

Roof Plan reference

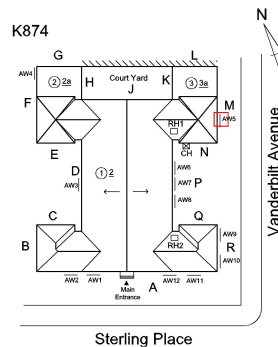

**NYC Department of Education
Building Condition Assessment Survey 2023 - 2024**

Architectural Inspection

K874

Question

Response

EXTERIOR

EXTERIOR WALLS

Elevation



Deficiency Quantity

10

Quantity Uom

S.F.

Potential Action

REMOVE AND REBUILD

Urgency of Action

PRIORITY 4

Purpose of Action

LEVEL 2

Deficiency Photo1



Facade M

Violations

No violations recorded.

Deficiency

BRICK: DETERIORATED JOINTS

Roof Plan reference

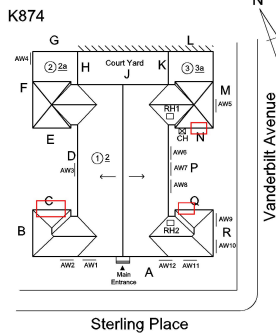

Elevation

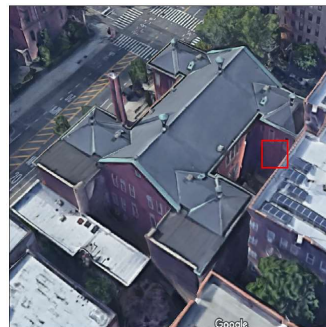

Deficiency Quantity

80

Quantity Uom

S.F.

Potential Action

REPOINT

**NYC Department of Education
Building Condition Assessment Survey 2023 - 2024**

Architectural Inspection

K874

Question

Response

EXTERIOR

EXTERIOR WALLS

Urgency of Action
Purpose of Action
Deficiency Photo1

PRIORITY 4
LEVEL 2

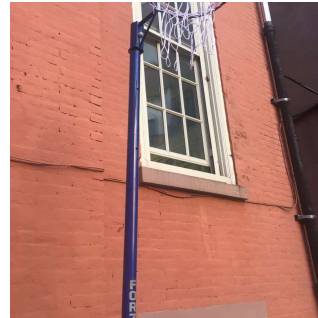

Facade C

Violations

No violations recorded.

Deficiency

BRICK: DETERIORATED MASONRY SILLS - MAJOR

Roof Plan reference

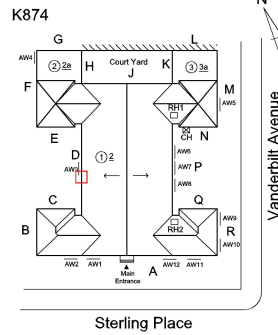

Elevation

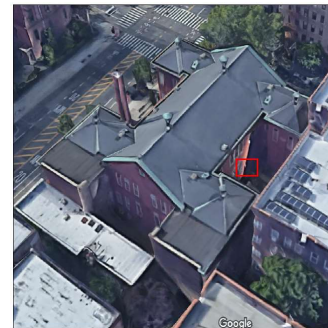

Deficiency Quantity

10

Quantity Uom

L.F.

Potential Action

REMOVE AND REPLACE

Urgency of Action

PRIORITY 4

Purpose of Action

LEVEL 2

Deficiency Photo1



Facade D

**NYC Department of Education
Building Condition Assessment Survey 2023 - 2024**

Architectural Inspection

K874

Question

Response

EXTERIOR

EXTERIOR WALLS

Violations

No violations recorded.

Deficiency

BRICK: DETERIORATED JOINTS

Roof Plan reference

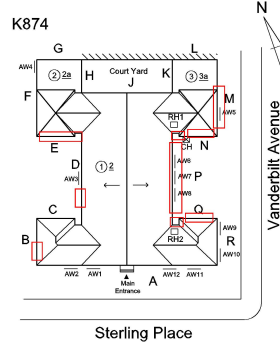

Elevation



Deficiency Quantity

400

Quantity Uom

S.F.

Potential Action

REPOINT

Urgency of Action

PRIORITY 3

Purpose of Action

LEVEL 2

Deficiency Photo1



Facade E

Violations

No violations recorded.

Deficiency

BRICK: WATER INFILTRATION IN INSTRUCTIONAL SPACE

Roof Plan reference

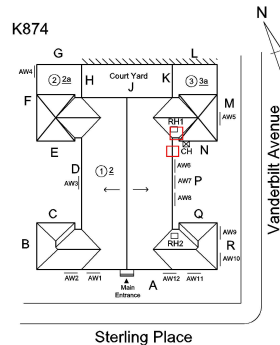

**NYC Department of Education
Building Condition Assessment Survey 2023 - 2024**

Architectural Inspection

K874

Question

Response

EXTERIOR

EXTERIOR WALLS

Elevation



Deficiency Quantity

300

Quantity Uom

S.F.

Potential Action

REPAIR

Urgency of Action

PRIORITY 5

Purpose of Action

LEVEL 2

Deficiency Photo1



Facade N - Stair D/2 shown, Facade N - Stair D/1, Facade P - Auditorium similar

Violations

No violations recorded.

Deficiency

BRICK: DETERIORATED CONTROL/EXPANSION JOINTS

Roof Plan reference

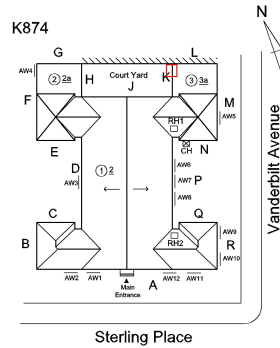

Elevation



Deficiency Quantity

30

Quantity Uom

L.F.

**NYC Department of Education
Building Condition Assessment Survey 2023 - 2024**

Architectural Inspection

K874

Question

Response

EXTERIOR

EXTERIOR WALLS

Potential Action
Urgency of Action
Purpose of Action
Deficiency Photo1

MAINTENANCE
PRIORITY 3
LEVEL 2



Facade K

Violations

No violations recorded.

Deficiency

BRICK: DETERIORATED MASONRY SILLS - MINOR

Roof Plan reference

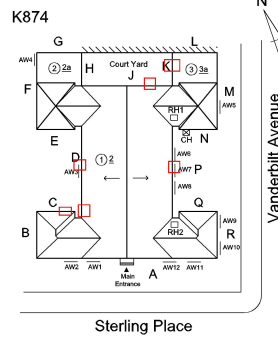

Elevation



Deficiency Quantity
Quantity Uom
Potential Action
Urgency of Action
Purpose of Action
Deficiency Photo1

40
L.F.
REPAIR
PRIORITY 3
LEVEL 2

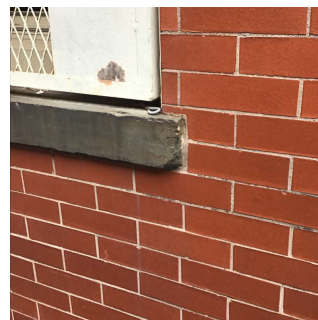

**NYC Department of Education
Building Condition Assessment Survey 2023 - 2024**

Architectural Inspection

K874

Question

Response

EXTERIOR

EXTERIOR WALLS

Violations

Facade J

No violations recorded.

Deficiency

STONE: CHIPPED/SPALLED/BROKEN PIECES - MAJOR

Roof Plan reference

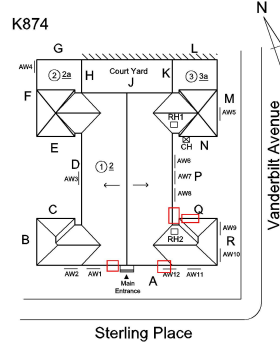

Elevation



Deficiency Quantity

40

Quantity Uom

S.F.

Potential Action

REPLACE

Urgency of Action

PRIORITY 4

Purpose of Action

LEVEL 2

Deficiency Photo1



Facade A

No violations recorded.

Deficiency

STONE: CHIPPED/SPALLED/BROKEN PIECES - MINOR

NYC Department of Education
Building Condition Assessment Survey 2023 - 2024

Architectural Inspection

K874

Question

Response

EXTERIOR

EXTERIOR WALLS

Roof Plan reference

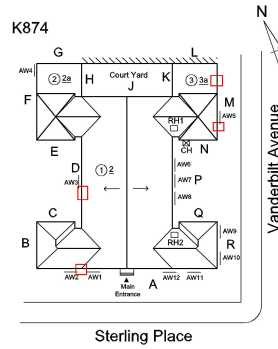

Elevation

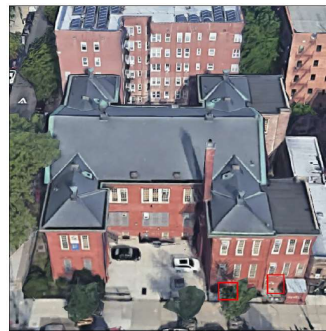

Deficiency Quantity

30

Quantity Uom

S.F.

Potential Action

REPAIR

Urgency of Action

PRIORITY 3

Purpose of Action

LEVEL 2

Deficiency Photo1

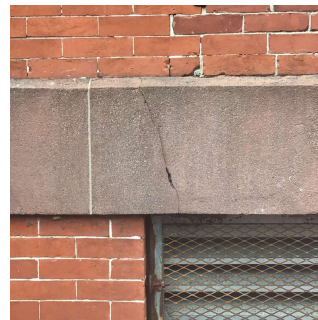

Facade M

Violations

No violations recorded.

Deficiency

BRICK: MINOR CRACKS AND SPALLING

Roof Plan reference

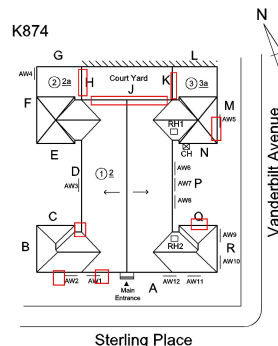

**NYC Department of Education
Building Condition Assessment Survey 2023 - 2024**

Architectural Inspection

K874

Question

Response

EXTERIOR

EXTERIOR WALLS

Elevation



Deficiency Quantity

100

Quantity Uom

S.F.

Potential Action

RESTITCH

Urgency of Action

PRIORITY 3

Purpose of Action

LEVEL 2

Deficiency Photo1



Facade A

No violations recorded.

Violations

Deficiency

BRICK: MINOR BULGING

Roof Plan reference

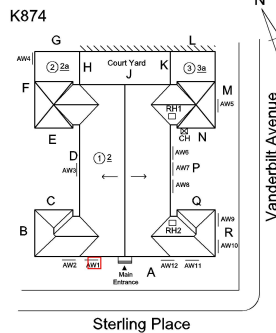

Elevation



Deficiency Quantity

20

Quantity Uom

S.F.

Potential Action

REMOVE AND REBUILD

NYC Department of Education
Building Condition Assessment Survey 2023 - 2024

Architectural Inspection

K874

Question	Response
----------	----------

EXTERIOR

EXTERIOR WALLS

Urgency of Action
 Purpose of Action
 Deficiency Photo1

PRIORITY 3
 LEVEL 4

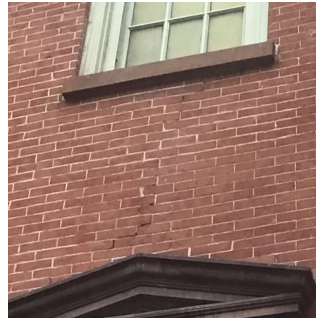

Facade A
 35663265K

Violations

EXTERIOR SOFFITS

Inspected

Condition

2 - Between Good and Fair

Deficiency

No deficiencies recorded

LOADING DOCK

Does not Exist

LOUVER

Inspected

Condition

2 - Between Good and Fair

Deficiency

No deficiencies recorded

PARAPETS

Inspected

Material Type(s)

Masonry

Replacement Quantity

200

Replacement Uom

C.F.

Instance on Roofs 2, 3

Inaccessible

Instance Quantity

200

Instance Quantity Uom

C.F.

PLAZA DECK

Does not Exist

ROOF

Inspected

Roofing

Inspected

Replacement Quantity

15,000

Replacement Uom

S.F.

ROOF HATCH/SMOKE HATCH

Inspected

Condition

2 - Between Good and Fair

Deficiency

No deficiencies recorded

LEADERS, GUTTERS, DOWNSPOUTS, SCUPPERS

Inspected

Condition

3 - Fair

Deficiency

CLOGGED

Roof Plan reference

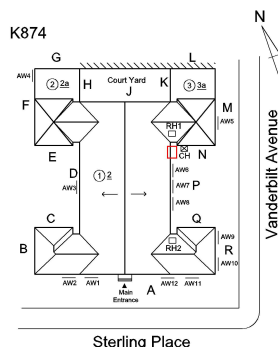

**NYC Department of Education
Building Condition Assessment Survey 2023 - 2024**

Architectural Inspection

K874

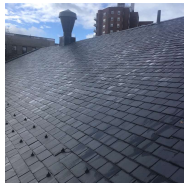
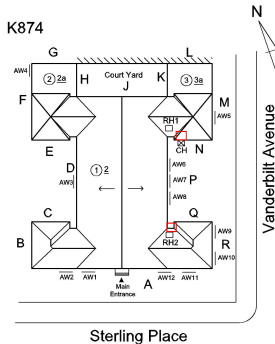
Question	Response
EXTERIOR	
ROOF	
Roofing	
LEADERS, GUTTERS, DOWNSPOUTS, SCUPPERS	
Deficiency Quantity	1
Quantity Uom	EACH
Potential Action	MAINTENANCE
Urgency of Action	PRIORITY 5
Purpose of Action	LEVEL 2
Deficiency Photo1	No photo recorded
Violations	No violations recorded.
ROOF BARRIER/FENCE	Does not Exist
ROOF CAGE	Does not Exist
ROOFING	Inspected
Instance on Slate Roof: Roof 1	Inspected
Instance Condition	3 - Fair
Instance Photo	
	Roof 1
Instance Quantity	13,500
Instance Quantity Uom	S.F.
Does the roof have major mechanical equipment sitting on Dunnage Steel less than 18" above the Roofing?	No
Does this roof instance have a Sustainable Roof System?	No
Do solar panels exist on these roofs?	No
Is/Are the roof(s) suitable for Solar Panel installation?	No
Installation Year	2003
Source of Installation	Custodial Staff
Deficiency	SLATE ROOF: ROOFING: DAMAGED OR MISSING TILES
Roof Plan reference	
Deficiency Quantity	20
Quantity Uom	S.F.
Potential Action	REPLACE
Urgency of Action	PRIORITY 4
Purpose of Action	LEVEL 2

**NYC Department of Education
Building Condition Assessment Survey 2023 - 2024**

Architectural Inspection

K874

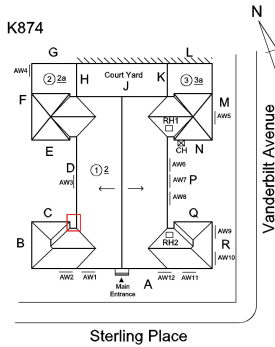
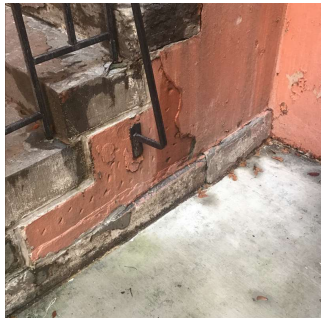
Question	Response
EXTERIOR	
ROOF	
Roofing	
ROOFING	
Deficiency Photo1	
	Roof 1 - Near CH
Violations	No violations recorded.
Instance on Modified Bitumen: Roofs 2, 3	Inaccessible
Instance Quantity	1,500
Instance Quantity Uom	S.F.
ROOFING DRAINS	Inaccessible
Specialties	Does not Exist
STAIRS/RAMPS: EXTERIOR	Inspected
BUILDING CHEEK/FLANK WALLS	Inspected
Condition	3 - Fair
Deficiency	CAST IN PLACE CONCRETE: CRACKS/SPALLING - MAJOR
Roof Plan reference	 <p>The diagram is a floor plan of the building, labeled K874. It shows a central courtyard area. Rooms are labeled with letters A through R. A red box highlights a specific area on the west side of the building, near rooms C, D, and E. The plan also shows the location of the Main Entrance and the Courtyard. The building is situated between Sterling Place and Vanderbilt Avenue.</p>
Deficiency Quantity	10
Quantity Uom	S.F.
Potential Action	REPLACE
Urgency of Action	PRIORITY 4
Purpose of Action	LEVEL 2
Deficiency Photo1	
	Facade C - Exit 2
Violations	No violations recorded.

**NYC Department of Education
Building Condition Assessment Survey 2023 - 2024**

Architectural Inspection

K874

Question

Response

EXTERIOR

STAIRS/RAMPS: EXTERIOR

BUILDING CHEEK/FLANK WALLS

Deficiency

Roof Plan reference

CAST IN PLACE CONCRETE: CRACKS/SPALLING - MINOR

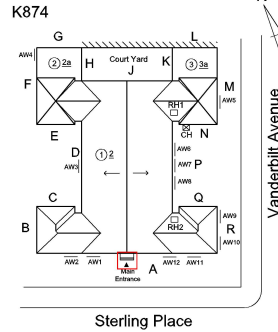

Deficiency Quantity
Quantity Uom
Potential Action
Urgency of Action
Purpose of Action
Deficiency Photo1

30
S.F.
REPAIR
PRIORITY 3
LEVEL 2

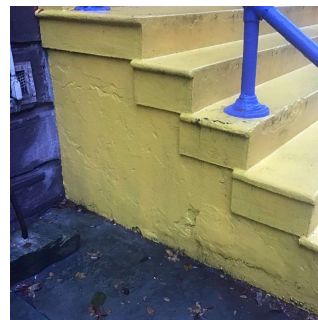

Facade A - Main Entrance

Violations

No violations recorded.

RAILINGS

Condition

Deficiency

Roof Plan reference

Inspected

3 - Fair

DAMAGED

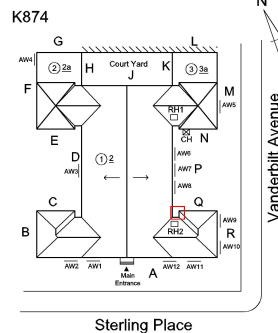

Deficiency Quantity
Quantity Uom
Potential Action
Urgency of Action
Purpose of Action

10
L.F.
REPLACE
PRIORITY 4
LEVEL 2

**NYC Department of Education
Building Condition Assessment Survey 2023 - 2024**

Architectural Inspection

K874

Question	Response
----------	----------

EXTERIOR

STAIRS/RAMPS: EXTERIOR

RAILINGS

Deficiency Photo1



Facade Q

Violations

No violations recorded.

Deficiency

MISSING RAILING

Roof Plan reference

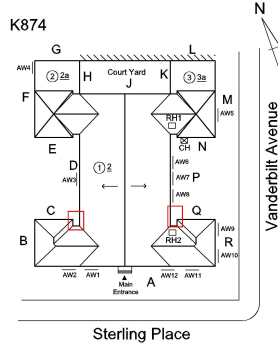

Deficiency Quantity

20

Quantity Uom

L.F.

Potential Action

REPLACE

Urgency of Action

PRIORITY 5

Purpose of Action

LEVEL 6

Deficiency Photo1

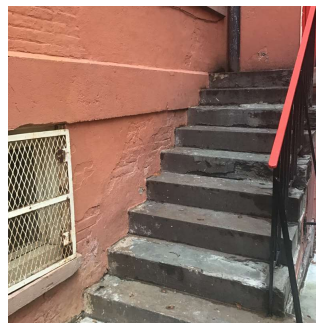

Facade C - Exit 2

Violations

No violations recorded.

STAIRS/RAMPS

Inspected

Condition

5 - Poor

Deficiency

CONCRETE: CRACKS/SPALLING - MAJOR

**NYC Department of Education
Building Condition Assessment Survey 2023 - 2024**

Architectural Inspection

K874

Question

Response

EXTERIOR

STAIRS/RAMPS: EXTERIOR

STAIRS/RAMPS

Roof Plan reference

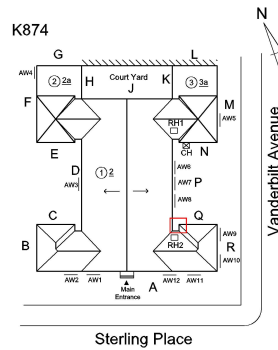

Deficiency Quantity
Quantity Uom
Potential Action
Urgency of Action
Purpose of Action
Deficiency Photo1

10
S.F.
REPLACE
PRIORITY 4
LEVEL 2

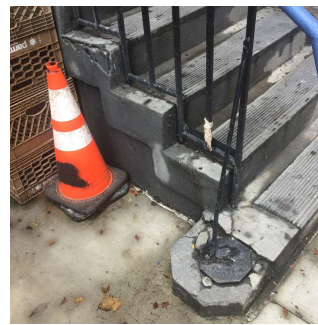

Facade Q
No violations recorded.

Violations

Deficiency

STONE: WORN-OUT TREAD/RISER/NOSING

Roof Plan reference

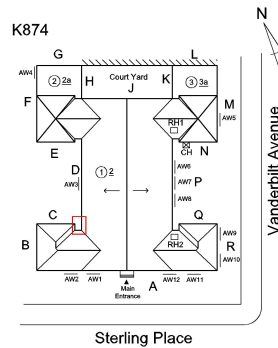

Deficiency Quantity
Quantity Uom
Potential Action
Urgency of Action
Purpose of Action

20
S.F.
REPLACE
PRIORITY 4
LEVEL 2

**NYC Department of Education
Building Condition Assessment Survey 2023 - 2024**

Architectural Inspection

K874

Question

Response

EXTERIOR

STAIRS/RAMPS: EXTERIOR

STAIRS/RAMPS

Deficiency Photo1

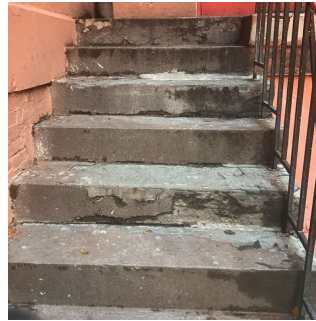

Facade C - Exit 2

Violations

No violations recorded.

Deficiency

STONE: CRACKS/SPALLING - MAJOR

Roof Plan reference

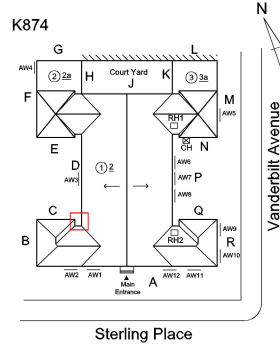

Deficiency Quantity

20

Quantity Uom

S.F.

Potential Action

REPLACE

Urgency of Action

PRIORITY 5

Purpose of Action

LEVEL 6

Deficiency Photo1



Facade C - Exit 2

Violations

No violations recorded.

Deficiency

METAL: RUST - MAJOR

**NYC Department of Education
Building Condition Assessment Survey 2023 - 2024**

Architectural Inspection

K874

Question

Response

EXTERIOR

STAIRS/RAMPS: EXTERIOR

STAIRS/RAMPS

Roof Plan reference

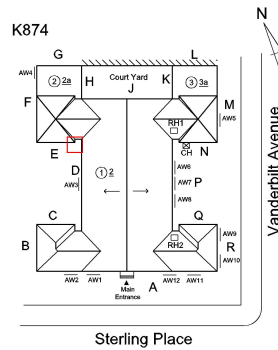

Deficiency Quantity
Quantity Uom
Potential Action
Urgency of Action
Purpose of Action
Deficiency Photo1

20
S.F.
REPLACE
PRIORITY 4
LEVEL 2

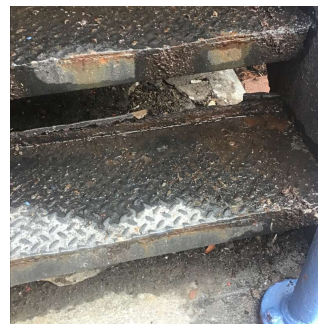

Facade N

No violations recorded.

Violations

Deficiency

STONE: CRACKS/SPALLING - MINOR

Roof Plan reference

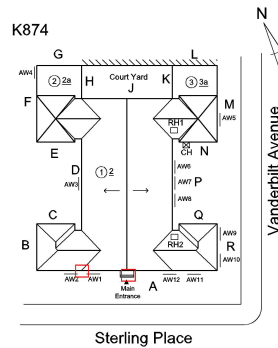

Deficiency Quantity
Quantity Uom
Potential Action
Urgency of Action
Purpose of Action

20
S.F.
REPAIR
PRIORITY 3
LEVEL 2

**NYC Department of Education
Building Condition Assessment Survey 2023 - 2024**

Architectural Inspection

K874

Question	Response
----------	----------

EXTERIOR

STAIRS/RAMPS: EXTERIOR

STAIRS/RAMPS

Deficiency Photo1



Facade A - Main Entrance

No violations recorded.

Violations

WINDOWS

Inspected

Replacement Quantity

5,000

Replacement Uom

S.F.

EXTERIOR GUARDS

Inspected

Condition

3 - Fair

Deficiency

DETERIORATED/TORN-OUT/MISSING

Roof Plan reference

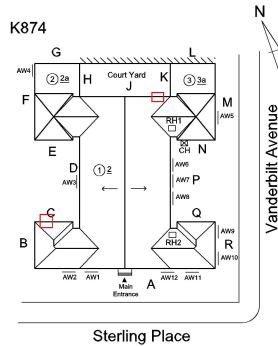

Elevation

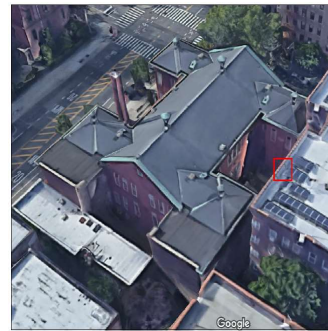

Deficiency Quantity

30

Quantity Uom

S.F.

Potential Action

REPLACE

Urgency of Action

PRIORITY 4

Purpose of Action

LEVEL 2

**NYC Department of Education
Building Condition Assessment Survey 2023 - 2024**

Architectural Inspection



K874

Question	Response
EXTERIOR	
WINDOWS	
EXTERIOR GUARDS	
Deficiency Photo1	
Violations	Facade C No violations recorded.
LINTELS	Inspected
Condition	2 - Between Good and Fair
Deficiency	No deficiencies recorded
WINDOWS	Inspected
Material Type(s)	Aluminum
Instance on Aluminum - Double Hung: All Facades	Inspected
Instance Condition	3 - Fair
Instance Quantity	5,000
Instance Quantity Uom	S.F.
Are these windows insulated	No
Installation Year	1995
Source of Installation	Custodial Staff
Deficiency	No deficiencies recorded
INTERIOR	Inspected
POOLS	Does not Exist
STRUCTURAL	Inspected
COLUMNS/BEAMS/BEARING WALLS	Inspected
Condition	3 - Fair
Deficiency	STEEL COLUMNS/BEAMS: DETERIORATED CONCRETE FIREPROOFING
Deficiency Location/Instance	Basement - Electrical Panel Room
Deficiency Quantity	20
Quantity Uom	S.F.
Potential Action	REPLACE
Urgency of Action	PRIORITY 4
Purpose of Action	LEVEL 5
Deficiency Photo1	
	Electrical Panel Room

**NYC Department of Education
Building Condition Assessment Survey 2023 - 2024**

Architectural Inspection

K874

Question	Response
INTERIOR	
STRUCTURAL	
COLUMNS/BEAMS/BEARING WALLS	Inspected
Violations	No violations recorded.
FLOOR STRUCTURE	Inspected
Condition	3 - Fair
Deficiency	CONCRETE SLAB ON GRADE: THRU CRACKS
Deficiency Location/Instance	Basement - Electrical Panel Room
Deficiency Quantity	80
Quantity Uom	S.F.
Potential Action	REPLACE
Urgency of Action	PRIORITY 4
Purpose of Action	LEVEL 5
Deficiency Photo1	
Violations	Basement - Electrical Panel Room No violations recorded.
FOUNDATION WALLS	Inspected
Material Type(s)	Concrete, Masonry
Condition	4 - Between Fair and Poor
Deficiency	BRICK: WATER INFILTRATION IN INSTRUCTIONAL SPACE
Deficiency Location/Instance	Basement - Stair D/Basement
Deficiency Quantity	100
Quantity Uom	S.F.
Potential Action	INSTALL WATERPROOFING
Urgency of Action	PRIORITY 5
Purpose of Action	LEVEL 5
Deficiency Photo1	
Violations	Stair D/Basement No violations recorded.
Deficiency	BRICK: DETERIORATED JOINTS
Deficiency Location/Instance	Basement - Boiler Room, Gas Meter Room
Deficiency Quantity	60
Quantity Uom	S.F.
Potential Action	REPOINT

**NYC Department of Education
Building Condition Assessment Survey 2023 - 2024**

Architectural Inspection

K874

Question

Response

INTERIOR

STRUCTURAL

FOUNDATION WALLS

Urgency of Action

PRIORITY 4

Purpose of Action

LEVEL 5

Deficiency Photo1



Gas Meter Room

Violations

No violations recorded.

Deficiency

BRICK: WATER INFILTRATION IN NON- INSTRUCTIONAL SPACE

Deficiency Location/Instance

Basement - Boiler Room

Deficiency Quantity

100

Quantity Uom

S.F.

Potential Action

INSTALL WATERPROOFING

Urgency of Action

PRIORITY 5

Purpose of Action

LEVEL 5

Deficiency Photo1

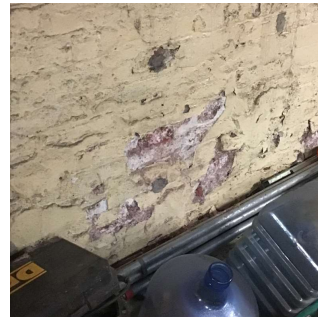

Boiler Room

Violations

No violations recorded.

Deficiency

BRICK: DETERIORATED JOINTS

Deficiency Location/Instance

Basement - Electrical Panel Room

Deficiency Quantity

10

Quantity Uom

S.F.

Potential Action

REPOINT

Urgency of Action

PRIORITY 3

Purpose of Action

LEVEL 5

**NYC Department of Education
Building Condition Assessment Survey 2023 - 2024**

Architectural Inspection



K874

Question	Response
INTERIOR	
STRUCTURAL	
FOUNDATION WALLS	
Deficiency Photo1	
Violations	Basement - Electrical Panel Room No violations recorded.
Deficiency	BRICK: CRACKED/SPALLED
Deficiency Location/Instance	Basement - Electrical Panel Room
Deficiency Quantity	10
Quantity Uom	S.F.
Potential Action	RESTITCH
Urgency of Action	PRIORITY 3
Purpose of Action	LEVEL 5
Deficiency Photo1	
Violations	Electrical Panel Room No violations recorded.
ROOF STRUCTURE	
Condition	Inspected
Deficiency	2 - Between Good and Fair
VAULTS-BUNKERS	
Deficiency	No deficiencies recorded
VAULTS-BUNKERS	
Deficiency	Does not Exist
AUDITORIUM	
Instance on 2nd Floor (180 seats)	Inspected
Ceiling	
Instance on 2nd Floor (180 seats)	Inspected
Condition	2 - Between Good and Fair
Deficiency	No deficiencies recorded
Door(s)	
Instance on 2nd Floor (180 seats)	Inspected
Condition	3 - Fair
Deficiency	METAL: DETERIORATED DOOR
Deficiency Location/Instance	Storage
Deficiency Quantity	1
Quantity Uom	EACH
Potential Action	MAINTENANCE

**NYC Department of Education
Building Condition Assessment Survey 2023 - 2024**

Architectural Inspection

K874

Question	Response
INTERIOR	
AUDITORIUM	
Door(s)	
Urgency of Action	PRIORITY 3
Purpose of Action	LEVEL 2
Deficiency Photo1	
Violations	Storage No violations recorded.
Fixed H/C Lift	
Instance on 2nd Floor (180 seats)	Does not Exist
Fixed Seating	
Instance on 2nd Floor (180 seats)	Inspected
Condition	3 - Fair
Deficiency	DAMAGED/BROKEN/INOPERABLE
Deficiency Location/Instance	Seat D/105
Deficiency Quantity	1
Quantity Uom	EACH
Potential Action	REPLACE
Urgency of Action	PRIORITY 5
Purpose of Action	LEVEL 6
Deficiency Photo1	
Violations	Seat D/105 No violations recorded.
Deficiency	DAMAGED/BROKEN/INOPERABLE
Deficiency Location/Instance	Seats A/107,D/102,103,104,O/102, and others
Deficiency Quantity	11
Quantity Uom	EACH
Potential Action	REPLACE
Urgency of Action	PRIORITY 3
Purpose of Action	LEVEL 2

**NYC Department of Education
Building Condition Assessment Survey 2023 - 2024**

Architectural Inspection

K874

Question	Response
INTERIOR	
AUDITORIUM	
Fixed Seating	
Deficiency Photo1	
	Seat A/107
Violations	No violations recorded.
Floor Finish	
Instance on 2nd Floor (180 seats)	Inspected
Condition	3 - Fair
Deficiency	WOOD: DAMAGED/DETERIORATED
Deficiency Location/Instance	Near Entrance, center, windows
Deficiency Quantity	200
Quantity Uom	S.F.
Potential Action	REPLACE
Urgency of Action	PRIORITY 3
Purpose of Action	LEVEL 2
Deficiency Photo1	
	Near Windows
Violations	No violations recorded.
Sliding-folding Partition	
Instance on 2nd Floor (180 seats)	Does not Exist
Stage	
Instance on 2nd Floor (180 seats)	Inspected
Stage	
Instance on 2nd Floor (180 seats)	Inspected
Condition	2 - Between Good and Fair
Deficiency	DAMAGED FLOOR
Deficiency Location/Instance	Center
Deficiency Quantity	10
Quantity Uom	S.F.
Potential Action	REPLACE
Urgency of Action	PRIORITY 3
Purpose of Action	LEVEL 2

**NYC Department of Education
Building Condition Assessment Survey 2023 - 2024**

Architectural Inspection



K874

Question	Response
INTERIOR	
AUDITORIUM	
Stage	
Stage	
Deficiency Photo1	
Violations	Center No violations recorded.
Deficiency	DAMAGED FASCIA
Deficiency Location/Instance	Right side, left side
Deficiency Quantity	10
Quantity Uom	S.F.
Potential Action	REPLACE
Urgency of Action	PRIORITY 3
Purpose of Action	LEVEL 2
Deficiency Photo1	
Violations	Left side No violations recorded.
Stage Curtain Rigging	Does not Exist
Instance on 2nd Floor (180 seats)	Does not Exist
Stage Curtains	Does not Exist
Instance on 2nd Floor (180 seats)	Does not Exist
Walls	
Instance on 2nd Floor (180 seats)	Inspected
Condition	2 - Between Good and Fair
Deficiency	PLASTER: CRACKS/SPALLING - ACTIVE LEAK
Deficiency Location/Instance	Near Entrance
Deficiency Quantity	20
Quantity Uom	S.F.
Potential Action	REPLACE
Urgency of Action	PRIORITY 5
Purpose of Action	LEVEL 2

**NYC Department of Education
Building Condition Assessment Survey 2023 - 2024**

Architectural Inspection

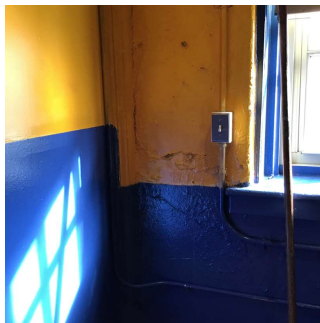
K874

Question	Response
INTERIOR	
AUDITORIUM	
Walls	
Deficiency Photo1	
Violations	Near Entrance No violations recorded.
Window Curtains/Shades/Blinds	
Instance on 2nd Floor (180 seats)	Inspected
Condition	3 - Fair
Deficiency	DAMAGED SHADES
Deficiency Location/Instance	Windows
Deficiency Quantity	60
Quantity Uom	S.F.
Potential Action	MAINTENANCE
Urgency of Action	PRIORITY 3
Purpose of Action	LEVEL 2
Deficiency Photo1	
Violations	Windows No violations recorded.
CAFETERIA	
Instance on Basement (2,000 SF)	Inspected
Ceiling	
Instance on Basement (2,000 SF)	Inspected
Condition	2 - Between Good and Fair
Deficiency	No deficiencies recorded
Door(s)	
Instance on Basement (2,000 SF)	Inspected
Condition	2 - Between Good and Fair
Deficiency	No deficiencies recorded
Fixed Equipment	
Instance on Basement (2,000 SF)	Does not Exist
Floor Finish	
Instance on Basement (2,000 SF)	Inspected
Condition	5 - Poor

NYC Department of Education
Building Condition Assessment Survey 2023 - 2024

Architectural Inspection

K874

Question	Response
----------	----------

INTERIOR

CAFETERIA

Floor Finish

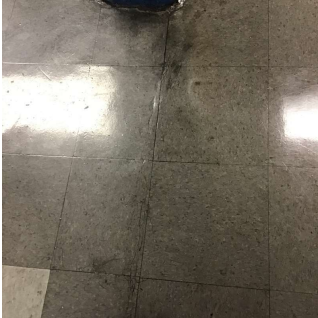
Deficiency	VINYL TILES: DETERIORATED SUBSTRATE
Deficiency Location/Instance	Near Entrance, Servery, center, windows
Deficiency Quantity	400
Quantity Uom	S.F.
Potential Action	REPLACE
Urgency of Action	PRIORITY 3
Purpose of Action	LEVEL 2
Deficiency Photo1	

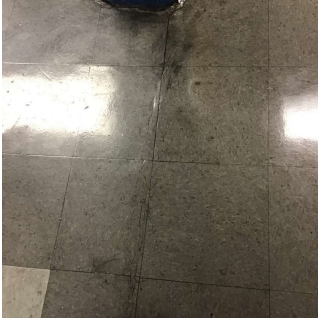

Violations	Near Entrance No violations recorded.
------------	--

Sliding-folding Partition

Instance on Basement (2,000 SF)	Does not Exist
---------------------------------	----------------

Stage

Instance on Basement (2,000 SF)	Does not Exist
---------------------------------	----------------

Walls

Instance on Basement (2,000 SF)	Inspected
Condition	2 - Between Good and Fair
Deficiency	No deficiencies recorded

Window Curtains/Shades/Blinds

Instance on Basement (2,000 SF)	Does not Exist
---------------------------------	----------------

CLASSROOMS/CORRIDORS/ADMIN SPACES

Ceiling



Condition	2 - Between Good and Fair
Deficiency	ACOUSTIC TILES: DAMAGED/MISSING
Deficiency Location/Instance	Corridor near Auditorium entrance
Deficiency Quantity	10
Quantity Uom	S.F.
Potential Action	REPLACE
Urgency of Action	PRIORITY 3
Purpose of Action	LEVEL 2
Deficiency Photo1	



**NYC Department of Education
Building Condition Assessment Survey 2023 - 2024**

Architectural Inspection

K874

Question	Response
INTERIOR	
CLASSROOMS/CORRIDORS/ADMIN SPACES	
Ceiling	
Violations	Corridor near Auditorium Entrance No violations recorded.
Deficiency	METAL PAN: DAMAGED/MISSING
Deficiency Location/Instance	Corridor near Room 213,115,106
Deficiency Quantity	30
Quantity Uom	S.F.
Potential Action	REPLACE
Urgency of Action	PRIORITY 3
Purpose of Action	LEVEL 2
Deficiency Photo1	
Violations	Corridor near Room 115 No violations recorded.
Door(s)	Inspected
Condition	5 - Poor
Deficiency	WOOD: DETERIORATED DOOR
Deficiency Location/Instance	Room 214,213,202,201,106, and others
Deficiency Quantity	6
Quantity Uom	EACH
Potential Action	MAINTENANCE
Urgency of Action	PRIORITY 3
Purpose of Action	LEVEL 2
Deficiency Photo1	
Violations	Room 214 No violations recorded.
Floor Finish	Inspected
Condition	3 - Fair
Deficiency	VINYL TILES: TRIPPING HAZARD - ELECTRICAL OUTLET
Deficiency Location/Instance	Room 210
Deficiency Quantity	20
Quantity Uom	S.F.
Potential Action	REMOVE

**NYC Department of Education
Building Condition Assessment Survey 2023 - 2024**

Architectural Inspection

K874

Question	Response
----------	----------

INTERIOR

CLASSROOMS/CORRIDORS/ADMIN SPACES

Floor Finish

Urgency of Action
Purpose of Action
Deficiency Photo1

PRIORITY 5
LEVEL 6



Room 210

Violations

No violations recorded.

Deficiency
Deficiency Location/Instance
Deficiency Quantity
Quantity Uom
Potential Action
Urgency of Action
Purpose of Action
Deficiency Photo1

VINYL TILES: BROKEN/DETERIORATED/MISSING TILES
Room 218,214, 212,210,208, and others
500
S.F.
REPLACE
PRIORITY 3
LEVEL 2



Room 214

Violations

No violations recorded.

Deficiency
Deficiency Location/Instance
Deficiency Quantity
Quantity Uom
Potential Action
Urgency of Action
Purpose of Action
Deficiency Photo1



WOOD: DAMAGED/DETERIORATED
Corridor near Room 210,209,207,115, 105, and others
500
S.F.
REPLACE
PRIORITY 3
LEVEL 2



**NYC Department of Education
Building Condition Assessment Survey 2023 - 2024**

Architectural Inspection

K874

Question	Response
INTERIOR	
CLASSROOMS/CORRIDORS/ADMIN SPACES	
Floor Finish	
Violations	Corridor near Room 115 No violations recorded.
Deficiency	TERRAZZO: CRACKS
Deficiency Location/Instance	Main Entrance Lobby
Deficiency Quantity	20
Quantity Uom	S.F.
Potential Action	REPLACE
Urgency of Action	PRIORITY 3
Purpose of Action	LEVEL 2
Deficiency Photo1	
Violations	Main Entrance Lobby No violations recorded.
Walls	Inspected
Condition	2 - Between Good and Fair
Deficiency	CERAMIC TILE: BROKEN/ MISSING
Deficiency Location/Instance	Main Entrance Lobby
Deficiency Quantity	20
Quantity Uom	S.F.
Potential Action	REPLACE
Urgency of Action	PRIORITY 3
Purpose of Action	LEVEL 2
Deficiency Photo1	
Violations	Main Entrance Lobby No violations recorded.
Deficiency	PLASTER: CRACKS/SPALLING
Deficiency Location/Instance	Room 212, 210,207,205,205A, and others
Deficiency Quantity	150
Quantity Uom	S.F.
Potential Action	REPLACE
Urgency of Action	PRIORITY 3
Purpose of Action	LEVEL 2

**NYC Department of Education
Building Condition Assessment Survey 2023 - 2024**

Architectural Inspection



K874

Question	Response
INTERIOR	
CLASSROOMS/CORRIDORS/ADMIN SPACES	
Walls	
Deficiency Photo1	
Violations	Room 212 No violations recorded.
Specialties	Does not Exist
GYMNASIUM	Does not Exist
INTERIOR DOOR HARDWARE	Inspected
Condition	3 - Fair
Deficiency	No deficiencies recorded
INTERIOR GUARDS	Inspected
Condition	2 - Between Good and Fair
Deficiency	No deficiencies recorded
KITCHEN	Inspected
Instance on Basement (200 SF)	Inspected
Ceiling	
Instance on Basement (200 SF)	Inspected
Condition	4 - Between Fair and Poor
Deficiency	GYPSUM BOARD: DAMAGED/DETERIORATED
Deficiency Location/Instance	Kitchen locker room, near Servery
Deficiency Quantity	20
Quantity Uom	S.F.
Potential Action	REPLACE
Urgency of Action	PRIORITY 3
Purpose of Action	LEVEL 2
Deficiency Photo1	
Violations	Kitchen locker room No violations recorded.
Door(s)	
Instance on Basement (200 SF)	Inspected
Condition	4 - Between Fair and Poor
Deficiency	METAL: DETERIORATED DOOR
Deficiency Location/Instance	Kitchen locker room

**NYC Department of Education
Building Condition Assessment Survey 2023 - 2024**

Architectural Inspection

K874

Question	Response
INTERIOR	
KITCHEN	
Door(s)	
Deficiency Quantity	1
Quantity Uom	EACH
Potential Action	MAINTENANCE
Urgency of Action	PRIORITY 3
Purpose of Action	LEVEL 2
Deficiency Photo1	
	Kitchen locker room
Violations	No violations recorded.
<hr/>	
Deficiency	WOOD: DETERIORATED DOOR
Deficiency Location/Instance	Storage
Deficiency Quantity	1
Quantity Uom	EACH
Potential Action	MAINTENANCE
Urgency of Action	PRIORITY 3
Purpose of Action	LEVEL 2
Deficiency Photo1	
	Storage
Violations	No violations recorded.
<hr/>	
Floor Finish	
Instance on Basement (200 SF)	Inspected
Condition	5 - Poor
Deficiency	CONCRETE: CRACKS
Deficiency Location/Instance	Near kitchen exit
Deficiency Quantity	10
Quantity Uom	S.F.
Potential Action	REPLACE
Urgency of Action	PRIORITY 5
Purpose of Action	LEVEL 6

**NYC Department of Education
Building Condition Assessment Survey 2023 - 2024**

Architectural Inspection

K874

Question	Response
INTERIOR	
KITCHEN	

Floor Finish

Deficiency Photo1



Near kitchen exit

Violations

No violations recorded.

Deficiency	VINYL TILES: BROKEN/DETERIORATED/MISSING TILES
Deficiency Location/Instance	Near Servery, center, sink
Deficiency Quantity	20
Quantity Uom	S.F.
Potential Action	REPLACE
Urgency of Action	PRIORITY 3
Purpose of Action	LEVEL 2
Deficiency Photo1	



Near servery

Violations

No violations recorded.

Walls

Instance on Basement (200 SF)	Inspected
Condition	3 - Fair
Deficiency	GYPSUM BOARD: DETERIORATED
Deficiency Location/Instance	Near Servery
Deficiency Quantity	10
Quantity Uom	S.F.
Potential Action	REPLACE
Urgency of Action	PRIORITY 3
Purpose of Action	LEVEL 2

**NYC Department of Education
Building Condition Assessment Survey 2023 - 2024**

Architectural Inspection

K874

Question	Response
INTERIOR	
KITCHEN	
Walls	
Deficiency Photo1	
Violations	Near Servery No violations recorded.
Deficiency	BRICK: CRACKS/SPALLING
Deficiency Location/Instance	Storage
Deficiency Quantity	10
Quantity Uom	S.F.
Potential Action	REPLACE
Urgency of Action	PRIORITY 3
Purpose of Action	LEVEL 2
Deficiency Photo1	
Violations	Storage No violations recorded.
LIBRARY	Inspected
Instance on Room 105	Inaccessible
LOCKER ROOM	Does not Exist
MULTI-PURPOSE ROOM	Inspected
Instance on Basement (2,000 SF)	Inspected
Ceiling	
Instance on Basement (2,000 SF)	Inspected
Condition	2 - Between Good and Fair
Deficiency	PLASTER: CRACKS/SPALLING
Deficiency Location/Instance	Near center
Deficiency Quantity	10
Quantity Uom	S.F.
Potential Action	REPLACE
Urgency of Action	PRIORITY 3
Purpose of Action	LEVEL 2

**NYC Department of Education
Building Condition Assessment Survey 2023 - 2024**

Architectural Inspection

K874

Question	Response
INTERIOR	
MULTI-PURPOSE ROOM	
Ceiling	
Deficiency Photo1	
Violations	Near center No violations recorded.
Door(s)	
Instance on Basement (2,000 SF)	Not Required
Fixed Equipment	
Instance on Basement (2,000 SF)	Does not Exist
Floor Finish	
Instance on Basement (2,000 SF)	Inspected
Condition	5 - Poor
Deficiency	VINYL TILES: DETERIORATED SUBSTRATE
Deficiency Location/Instance	Near cafeteria
Deficiency Quantity	200
Quantity Uom	S.F.
Potential Action	REPLACE
Urgency of Action	PRIORITY 3
Purpose of Action	LEVEL 2
Deficiency Photo1	
Violations	Near cafeteria No violations recorded.
Deficiency	VINYL TILES: BROKEN/DETERIORATED/MISSING TILES
Deficiency Location/Instance	Near center, windows
Deficiency Quantity	50
Quantity Uom	S.F.
Potential Action	REPLACE
Urgency of Action	PRIORITY 3
Purpose of Action	LEVEL 2

**NYC Department of Education
Building Condition Assessment Survey 2023 - 2024**

Architectural Inspection

K874

Question	Response
INTERIOR	
MULTI-PURPOSE ROOM	
Floor Finish	
Deficiency Photo1	
	Near center
Violations	No violations recorded.
Sliding-folding Partition	
Instance on Basement (2,000 SF)	Does not Exist
Stage	
Instance on Basement (2,000 SF)	Does not Exist
Walls	
Instance on Basement (2,000 SF)	Inspected
Condition	2 - Between Good and Fair
Deficiency	WALL PADDING: DETERIORATED
Deficiency Location/Instance	Near center
Deficiency Quantity	20
Quantity Uom	S.F.
Potential Action	REPLACE
Urgency of Action	PRIORITY 3
Purpose of Action	LEVEL 2
Deficiency Photo1	
	Near center
Violations	No violations recorded.
Window Curtains/Shades/Blinds	
Instance on Basement (2,000 SF)	Does not Exist
SCIENCE DEMO ROOM	Does not Exist
SCIENCE LAB	Inspected
Instance on Room 214	Inspected
Alternative use	No
Fixed Equipment	
Instance on Room 214	Inspected
Condition	2 - Between Good and Fair
Deficiency	No deficiencies recorded
SCIENCE PREP ROOM	Does not Exist

NYC Department of Education
Building Condition Assessment Survey 2023 - 2024

Architectural Inspection

K874

Question	Response
INTERIOR	
SCIENCE PREP ROOM	Does not Exist
SHOWER ROOM	Does not Exist
STAIRS/RAMPS: INTERIOR	Inspected
Do Letter Stair Signs Exist?	Partially
Ceiling	Inspected
Condition	2 - Between Good and Fair
Deficiency	No deficiencies recorded
Door(s)	Inspected
Condition	5 - Poor
Deficiency	WOOD: DETERIORATED DOOR
Deficiency Location/Instance	Stair C/Basement, E/Basement
Deficiency Quantity	2
Quantity Uom	EACH
Potential Action	MAINTENANCE
Urgency of Action	PRIORITY 3
Purpose of Action	LEVEL 2
Deficiency Photo1	
Violations	Stair E/Basement No violations recorded.
Partition	Inspected
Condition	2 - Between Good and Fair
Deficiency	GLASS PANEL: DAMAGED/DETERIORATED
Deficiency Location/Instance	Stair C/Basement,2, E/Basement
Deficiency Quantity	20
Quantity Uom	S.F.
Potential Action	REPLACE
Urgency of Action	PRIORITY 3
Purpose of Action	LEVEL 2
Deficiency Photo1	
Violations	Stair C/Basement No violations recorded.
Railings	Inspected
Condition	5 - Poor

**NYC Department of Education
Building Condition Assessment Survey 2023 - 2024**

Architectural Inspection

K874

Question	Response
INTERIOR	
STAIRS/RAMPS: INTERIOR	Inspected
Railings	
Deficiency	METAL: MISSING
Deficiency Location/Instance	Stair B/1, C/Basement, D/1
Deficiency Quantity	45
Quantity Uom	L.F.
Potential Action	REPLACE
Urgency of Action	PRIORITY 5
Purpose of Action	LEVEL 6
Deficiency Photo1	
Violations	Stair B/1 No violations recorded.
Stairs and Landings	
Condition	Inspected
Deficiency	2 - Between Good and Fair
Deficiency	VINYL TILES: BROKEN/DETERIORATED/MISSING TILES
Deficiency Location/Instance	Stair C/Basement
Deficiency Quantity	10
Quantity Uom	S.F.
Potential Action	REPLACE
Urgency of Action	PRIORITY 3
Purpose of Action	LEVEL 2
Deficiency Photo1	
Violations	Stair C/Basement No violations recorded.
Deficiency	ROLLED ASPHALT: CRACKS
Deficiency Location/Instance	Main Entrance Lobby Stair
Deficiency Quantity	50
Quantity Uom	S.F.
Potential Action	REPLACE
Urgency of Action	PRIORITY 3
Purpose of Action	LEVEL 2

**NYC Department of Education
Building Condition Assessment Survey 2023 - 2024**

Architectural Inspection

K874

Question	Response
----------	----------

INTERIOR

STAIRS/RAMPS: INTERIOR

Stairs and Landings

Deficiency Photo1



Main Entrance Lobby

Violations

No violations recorded.

Walls

Inspected

Condition

3 - Fair

Deficiency

PLASTER: CRACKS/SPALLING

Deficiency Location/Instance

Stair D/Basement

Deficiency Quantity

10

Quantity Uom

S.F.

Potential Action

REPLACE

Urgency of Action

PRIORITY 3

Purpose of Action

LEVEL 2

Deficiency Photo1

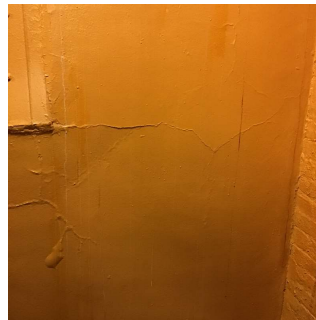

Stair D/Basement

Violations

No violations recorded.

Deficiency

PLASTER: CRACKS/SPALLING - ACTIVE LEAK

Deficiency Location/Instance

Stair D/Basement,1,2

Deficiency Quantity

30

Quantity Uom

S.F.

Potential Action

REPLACE

Urgency of Action

PRIORITY 5

Purpose of Action

LEVEL 2

Deficiency Photo1

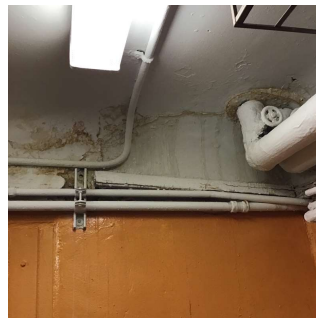

**NYC Department of Education
Building Condition Assessment Survey 2023 - 2024**

Architectural Inspection



K874

Question	Response
INTERIOR	
STAIRS/RAMPS: INTERIOR	
Walls	
Violations	Stair D/Basement No violations recorded.
Deficiency	CERAMIC TILE: BROKEN/ MISSING
Deficiency Location/Instance	Main Entrance Lobby
Deficiency Quantity	10
Quantity Uom	S.F.
Potential Action	REPLACE
Urgency of Action	PRIORITY 3
Purpose of Action	LEVEL 2
Deficiency Photo1	
Violations	Main Entrance Lobby No violations recorded.
TOILET ROOMS - STAFF	
Ceiling	Inspected
Condition	2 - Between Good and Fair
Deficiency	No deficiencies recorded
Door(s)	Inspected
Condition	5 - Poor
Deficiency	WOOD: DETERIORATED DOOR
Deficiency Location/Instance	2nd Floor - Men
Deficiency Quantity	1
Quantity Uom	EACH
Potential Action	MAINTENANCE
Urgency of Action	PRIORITY 3
Purpose of Action	LEVEL 2
Deficiency Photo1	
Violations	2nd Floor - Men No violations recorded.
Floor Finish	
Condition	5 - Poor

**NYC Department of Education
Building Condition Assessment Survey 2023 - 2024**

Architectural Inspection

K874

Question	Response
INTERIOR	
TOILET ROOMS - STAFF	
Floor Finish	
Deficiency	CERAMIC TILE: BROKEN/MISSING TILES
Deficiency Location/Instance	2nd Floor Womens, Mens
Deficiency Quantity	20
Quantity Uom	S.F.
Potential Action	REPLACE
Urgency of Action	PRIORITY 3
Purpose of Action	LEVEL 2
Deficiency Photo1	
Violations	2nd Floor - Women No violations recorded.
Deficiency	CONCRETE: CRACKS
Deficiency Location/Instance	Kitchen staff
Deficiency Quantity	10
Quantity Uom	S.F.
Potential Action	REPLACE
Urgency of Action	PRIORITY 3
Purpose of Action	LEVEL 2
Deficiency Photo1	
Violations	Kitchen staff No violations recorded.
Stalls	Inspected
Condition	5 - Poor
Deficiency	BROKEN/MISSING
Deficiency Location/Instance	Kitchen staff
Deficiency Quantity	1
Quantity Uom	EACH
Potential Action	REPLACE
Urgency of Action	PRIORITY 3
Purpose of Action	LEVEL 2

**NYC Department of Education
Building Condition Assessment Survey 2023 - 2024**

Architectural Inspection

K874

Question	Response
INTERIOR	
TOILET ROOMS - STAFF	
Stalls	
Deficiency Photo1	
Violations	Kitchen staff No violations recorded.
Walls	Inspected
Condition	2 - Between Good and Fair
Deficiency	PLASTER: CRACKS/SPALLING
Deficiency Location/Instance	2nd Floor - Men
Deficiency Quantity	20
Quantity Uom	S.F.
Potential Action	REPLACE
Urgency of Action	PRIORITY 3
Purpose of Action	LEVEL 2
Deficiency Photo1	
Violations	2nd Floor - Men No violations recorded.
TOILET ROOMS - STUDENTS	
Ceiling	Inspected
Condition	1 - Good
Deficiency	No deficiencies recorded
Door(s)	Inspected
Condition	2 - Between Good and Fair
Deficiency	No deficiencies recorded
Floor Finish	Inspected
Condition	2 - Between Good and Fair
Deficiency	CERAMIC TILE: BROKEN/MISSING TILES
Deficiency Location/Instance	Basement - Girls, Boys
Deficiency Quantity	10
Quantity Uom	S.F.
Potential Action	REPLACE
Urgency of Action	PRIORITY 3
Purpose of Action	LEVEL 2

**NYC Department of Education
Building Condition Assessment Survey 2023 - 2024**

Architectural Inspection

K874

Question	Response
INTERIOR	
TOILET ROOMS - STUDENTS	
Floor Finish	
Deficiency Photo1	
Violations	Basement - Girls No violations recorded.
Stalls	Inspected
Condition	1 - Good
Deficiency	No deficiencies recorded
Walls	Inspected
Condition	1 - Good
Deficiency	No deficiencies recorded
LIFE SAFETY	Inspected
F.D. HOLDING AREA	Does not Exist
STEEL STAIRS	Does not Exist
SITE	Inspected
CONTAINERIZATION	Does not Exist
Drainage System for Asphalt	Does not Exist
Drainage System for Concrete	Inspected
Catch Basins/Manhole - Surrounded by concrete	Inspected
Condition	2 - Between Good and Fair
Deficiency	No deficiencies recorded
Culverts - Concrete Covering	Does not Exist
Drainage System for Soil	Does not Exist
DRINKING FOUNTAINS	Does not Exist
FENCES	Inspected
Condition	4 - Between Fair and Poor
Deficiency	CONCRETE CURB: DAMAGED/DETERIORATED
Deficiency Location/Instance	Along Vanderbilt Avenue
Deficiency Quantity	20
Quantity Uom	S.F.
Potential Action	REPLACE
Urgency of Action	PRIORITY 3
Purpose of Action	LEVEL 2

**NYC Department of Education
Building Condition Assessment Survey 2023 - 2024**

Architectural Inspection

K874

Question

Response

SITE

FENCES

Deficiency Photo1

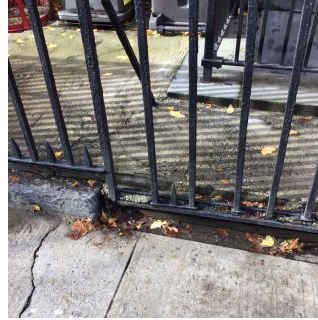

Along Vanderbilt Avenue
No violations recorded.

Violations

Deficiency

WROUGHT IRON: MISSING SECTIONS

Deficiency Location/Instance

Entrance Along Sterling Street, Vanderbilt Avenue

Deficiency Quantity

80

Quantity Uom

S.F.

Potential Action

REPLACE

Urgency of Action

PRIORITY 4

Purpose of Action

LEVEL 4

Deficiency Photo1



Entrance Along Sterling Street
35663264Z

Violations

Deficiency

CHAIN LINK: RUST - MAJOR

Deficiency Location/Instance

Near Courtyard West, Along Sterling Place

Deficiency Quantity

800

Quantity Uom

S.F.

Potential Action

REPLACE

Urgency of Action

PRIORITY 3

Purpose of Action

LEVEL 2

Deficiency Photo1

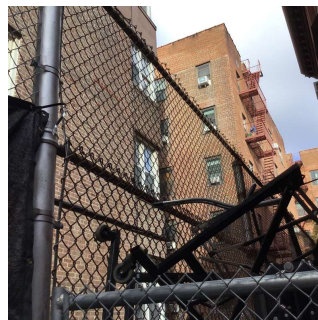

Near Courtyard West
No violations recorded.

Violations



IRRIGATION SYSTEM

Does not Exist

NYC Department of Education
Building Condition Assessment Survey 2023 - 2024

Architectural Inspection



K874

Question	Response
SITE	
PAVING	Inspected
Student Non-Use	Inspected
Gravel Exists?	No
Asphalt	Does not Exist
Concrete	Inspected
Condition	2 - Between Good and Fair
Deficiency	DAMAGED/DETERIORATED/MISSING SECTIONS
Deficiency Location/Instance	Along Vanderbilt Avenue
Deficiency Quantity	25
Quantity Uom	S.F.
Potential Action	REPLACE
Urgency of Action	PRIORITY 3
Purpose of Action	LEVEL 2
Deficiency Photo1	
Violations	Along Vanderbilt Avenue No violations recorded.
Pavers	Does not Exist
Student Use	Inspected
Gravel Exists?	No
Asphalt	Does not Exist
Concrete	Inspected
Condition	3 - Fair
Deficiency	DAMAGED/DETERIORATED/MISSING SECTIONS
Deficiency Location/Instance	Courtyard West, Courtyard along Vanderbilt Avenue
Deficiency Quantity	275
Quantity Uom	S.F.
Potential Action	REPLACE
Urgency of Action	PRIORITY 3
Purpose of Action	LEVEL 2
Deficiency Photo1	
Violations	Courtyard - West No violations recorded.

**NYC Department of Education
Building Condition Assessment Survey 2023 - 2024**

Architectural Inspection

K874

Question	Response
SITE	
PAVING	
Student Use	Inspected
Pavers	Inspected
Condition	2 - Between Good and Fair
Deficiency	No deficiencies recorded
Site Sidewalks & Walkways	Inspected
Asphalt	Does not Exist
Concrete	Inspected
Condition	3 - Fair
Deficiency	DAMAGED/DETERIORATED/MISSING SECTIONS
Deficiency Location/Instance	Near Courtyard West
Deficiency Quantity	75
Quantity Uom	S.F.
Potential Action	REPLACE
Urgency of Action	PRIORITY 3
Purpose of Action	LEVEL 2
Deficiency Photo1	
Violations	Near Courtyard West No violations recorded.
Pavers	Does not Exist
DOT Sidewalk	Inspected
Asphalt	Does not Exist
Concrete	Inspected
Condition	4 - Between Fair and Poor
Deficiency	HEAVING
Deficiency Location/Instance	Along Sterling Place, Vanderbilt Avenue
Deficiency Quantity	100
Quantity Uom	S.F.
Potential Action	REPLACE
Urgency of Action	PRIORITY 3
Purpose of Action	LEVEL 2
Deficiency Photo1	
	Along Sterling Place

**NYC Department of Education
Building Condition Assessment Survey 2023 - 2024**

Architectural Inspection

K874

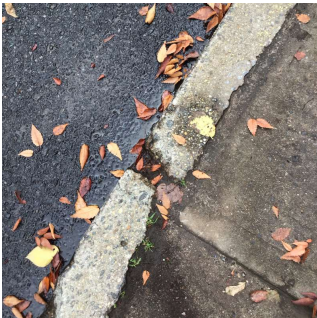
Question	Response
SITE	
PAVING	
DOT Sidewalk	
Concrete	
Violations	No violations recorded.
Deficiency	DAMAGED/DETERIORATED/MISSING SECTIONS
Deficiency Location/Instance	Along Sterling Place, Vanderbilt Avenue
Deficiency Quantity	700
Quantity Uom	S.F.
Potential Action	REPLACE
Urgency of Action	PRIORITY 3
Purpose of Action	LEVEL 2
Deficiency Photo1	
Violations	Along Sterling Place No violations recorded.
Deficiency	DAMAGED CURBS
Deficiency Location/Instance	Along Sterling Place, Vanderbilt Avenue
Deficiency Quantity	185
Quantity Uom	L.F.
Potential Action	REPLACE
Urgency of Action	PRIORITY 3
Purpose of Action	LEVEL 2
Deficiency Photo1	
Violations	Along Sterling Place No violations recorded.
Pavers	Does not Exist
PLAYGROUNDS	Inspected
Instance on Courtyard North	Inspected
Benches	
Instance on Courtyard North	Does not Exist
Fence	
Instance on Courtyard North	Does not Exist
Pavement	

NYC Department of Education
Building Condition Assessment Survey 2023 - 2024

Architectural Inspection

K874

Question	Response
SITE	
PLAYGROUNDS	
Pavement	
Instance on Courtyard North	Inspected
Condition	2 - Between Good and Fair
Deficiency	No deficiencies recorded
Play Equipment	
Instance on Courtyard North	Does not Exist
Safety Surfacing	
Instance on Courtyard North	Inspected
Condition	2 - Between Good and Fair
Deficiency	No deficiencies recorded
Unpaved Area	
Instance on Courtyard North	Does not Exist
PLAYING SURFACE	Inspected
Playing Field	Inspected
Instance on Courtyard West	Inspected
Instance Condition	2 - Between Good and Fair
Deficiency	No deficiencies recorded
Running Track	Does not Exist
RETAINING WALLS	Inspected
Are there any Retaining Walls 6' OR higher facing public street/sidewalk?	No
Condition	2 - Between Good and Fair
Deficiency	CAST IN PLACE CONCRETE: CRACKS/SPALLING - MAJOR
Deficiency Location/Instance	Courtyard West
Deficiency Quantity	10
Quantity Uom	S.F.
Potential Action	REPLACE
Urgency of Action	PRIORITY 3
Purpose of Action	LEVEL 2
Deficiency Photo1	
Violations	Courtyard West No violations recorded.
SEATING	Inspected
Benches	Inspected
Concrete	Does not Exist
Metal/Wood/Plastic	Inspected
Condition	2 - Between Good and Fair
Deficiency	No deficiencies recorded
Bleachers	Does not Exist
SITE WALLS (NOT RETAINING WALLS)	Does not Exist

NYC Department of Education
Building Condition Assessment Survey 2023 - 2024

Architectural Inspection

K874

Question	Response
SITE	Inspected
STAIRS/RAMPS: EXTERIOR	Does not Exist
ARTWORK	Does not Exist