

NYC Department of Education
Building Condition Assessment Survey 2023 - 2024

Architectural Inspection

Q053

Asset: I.S. 53 - QUEENS, 10-45 NAMEOKE STREET, New York, 11691

Inspection Id	Inspection Type	Time In	Last Edited
SA : Q053	Architectural - Senior	2024-04-29 7:38 AM	2024-05-07 4:34 PM
AA : Q053	Architectural - Associate	2024-04-29 7:36 AM	2024-05-08 7:28 PM

Asset Data

Question	Answer
Was the building fully accessible for inspection	Yes
Building Square Footage	164,000
Comments on the Area (for Athletic Field, Playing Surfaces, Leased Spaces)	None
Comments on the Stories (Floors) plus Basements	4+B
Comments on the Number of Classrooms	71
Comments on the Year Built	1972
Student Population	1,295
Staff Population	295
Weather	Fair
Principal(s) Information	
Principal Name	Zoanne Wilkins
Organization	I.S. 53 - Queens
Did you meet with this Principal?	No
Did this Principal provide feedback?	Yes
Summary of Principal's Feedback	A Principal questionnaire form was returned with the following comments: 1. Some of the newly installed Windows have broken panes. 2. The heating system needs to be balanced.
Principal Name	Doris Lee
Organization	Village Academy - Queens
Did you meet with this Principal?	No
Did this Principal provide feedback?	No
Principal Name	Kenneth Zhang
Organization	Success Academy Middle School - Queens
Did you meet with this Principal?	No
Did this Principal provide feedback?	No
Principal Name	Danielle Peña
Organization	Success Academy Elementary - Queens
Did you meet with this Principal?	No
Did this Principal provide feedback?	No
Custodian	Robert Gene Jr.
Fireman	Carmela Bridges

Facade Photo



Nameoke Street - Northwest view

Main Entrance Photo



Facade A - Nameoke Street

Roof Photo



Roof 1 - South view

NYC Department of Education
Building Condition Assessment Survey 2023 - 2024

Architectural Inspection

Q053

Have any Systems/Major Building Components been upgraded?

Yes

Systems: Windows, Window Guards replacement; Plaza Deck replacement; Leaders and Gutters, Roof Barrier replacement; New Greenhouse, Partial Exterior Walls, Exterior Soffits repairs.

Year: 2023

Systems: Roofs and Flashing, Parapets and Coping, Chimney, Limited Skylights (SK4, SK5, SK6), Exterior Doors at Exits 3 and 5 replaced.

Year: 2021

Have there been any Building Additions?

No



Tandem Schools?

No

Leased Space?

No

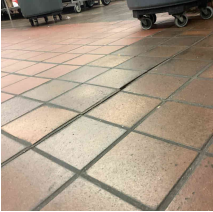
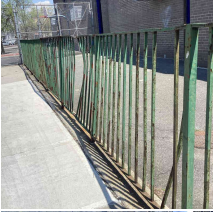
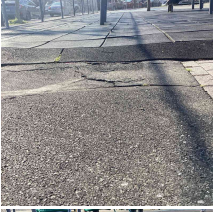
Priority Condition

Priority Condition Exist Last Year?	Priority Category	Condition Description	Component Affected	Location Description	Person(s) Notified	Person(s) Title	PhotoImage
No	Tripping Hazard	Heaving Concrete is a potential tripping hazard	SITE PAVING DOT Sidewalk Concrete	Beach 18th Street	Robert Gene Jr.	Custodian	
No	Tripping Hazard	Heaving Floor, near center is a tripping hazard condition	INTERIOR KITCHEN Floor Finish	Near center	Robert Gene Jr.	Custodian	
Yes	Potential Falling Debris	Severely damage and leaning forward Fence is a Potential safety Hazard Condition	SITE FENCES	Beach 18th Street, Nameoke Street	Robert Gene Jr.	Custodian	
Yes	Tripping Hazard	Severely heaving asphalt paving caused by tree roots is a tripping hazard Hazard Condition	SITE PAVING Student Use Asphalt	Playground Perimeter , Neighbors Limits	Robert Gene Jr.	Custodian	
Yes	Tripping Hazard	Severely Heaving Safety Surfacing caused by tree roots is a tripping hazard Condition	SITE PLAYGROUN DS Safety Surfacing	Near Bayport Place Entrance, Playground Perimeter	Robert Gene Jr.	Custodian	

Structural Engineer Required

Structural Condition Type	Condition Description	Component Affected	Location Description	Person(s) Notified	Person(s) Title	PhotoImage
No condition recorded						

Programmatic Accessibility

NYC Department of Education
Building Condition Assessment Survey 2023 - 2024

Architectural Inspection

Q053

Programmatic Accessibility Status Question	Response
Is the primary or secondary entrance on an accessible route?	Yes
Is the building a multi-story building?	Yes
Are all floors of the building accessible through compliant means?	Yes
Accessible classrooms exists on each floor?	Yes
Boys and Girls or Unisex accessible toilets exist on at least every other floor?	Yes
If the following spaces exist, are they ALL accessible? Art Room, Auditorium, Cafeteria, Computer, Gymnasiums, Library, Multipurpose Room, Science Labs	Yes

Physical Breakdown Structure	Exists	Required	Complies	Deficiency	Assistive Listening System	Fire Alarm Strobe
------------------------------	--------	----------	----------	------------	----------------------------	-------------------

PROGRAMMATIC ACCESSIBILITY

Exterior Routes

Exterior Entrances & Exits			Yes			
Exterior H/C Lifts	Yes		Yes			
Exterior Ramps and Railings	Yes		Yes			

Interior Routes

Corridor and Lobby H/C Lifts	No	No				
Interior Corridor Doors and Hardware	Yes		Yes			
Interior Corridors and Lobbies			Yes			
Interior Elevators	Yes		Yes			
Interior Lobby Doors and Hardware			Yes			
Interior Ramps	Yes		Yes			

Rooms & Spaces

Art Rooms	Rooms 110, 205, 404	Yes		Yes		
Auditorium	3rd Floor	Yes		Yes	FM System	Yes
Cafeteria	1st Floor	Yes		Yes	FM System	Yes
Classrooms	1st-4th Floor	Yes		Yes		
Computer Rooms		No				
Gymnasium	1st Floor	Yes		Yes	FM System	Yes
Library	Room 347	Yes		Yes		
Main Office	Room 109 (I.S. 53); Room 266 (Success Academy Middle School); Room 311 (Success Academy Elementary); Room 447 (Village Academy)	Yes		Yes		
Multi-purpose Room		No				
Nurse's Room	Room 113	Yes		Yes		
Pool		No				
Science Lab	Rooms 279, 408	Yes		Yes		
Toilet Rooms (Boys)	1st-3rd Floor	Yes		Yes		
Toilet Rooms (Girls)	1st-3rd Floor	Yes		Yes		
Toilet Rooms (Staff)	1st-4th Floor	Yes		Yes		

**NYC Department of Education
Building Condition Assessment Survey 2023 - 2024**

Architectural Inspection

Q053

Building Template

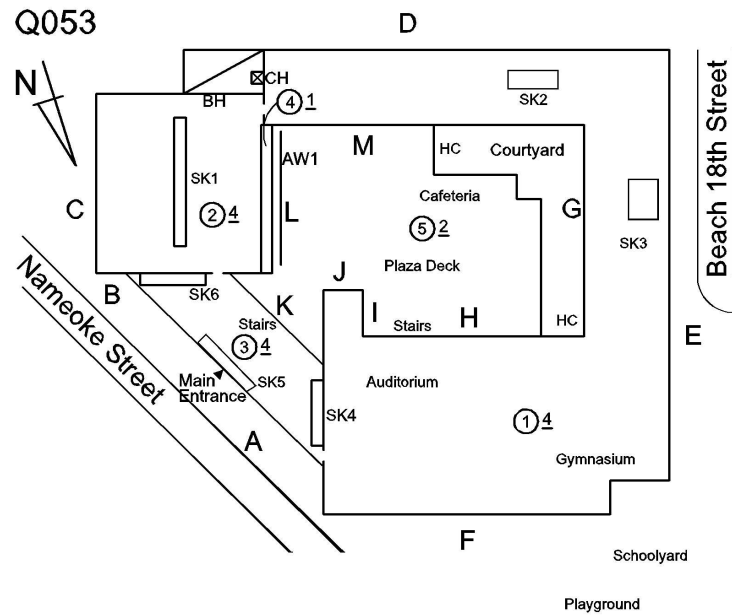

Inspection

Question	Response
Architectural	
EXTERIOR	Inspected
AREAWAY	Inspected
Instance on AW1	Inspected
Instance Condition	2 - Between Good and Fair
Instance Quantity	1
Instance Quantity Uom	EACH
Deficiency	No deficiencies recorded
AWNINGS AND CANOPIES	Does not Exist
CHIMNEY	Inspected
Material Type(s)	Masonry
Condition	1 - Good
Deficiency	No deficiencies recorded
COPING	Inspected
Condition	1 - Good
Deficiency	No deficiencies recorded
CORNICE	Does not Exist
DOORS	Inspected
DOORS AND FRAMES	Inspected
Condition	5 - Poor
Deficiency	METAL CLAD: DETERIORATED DOOR AND FRAME - MAJOR DETERIORATION

**NYC Department of Education
Building Condition Assessment Survey 2023 - 2024**

Architectural Inspection

Q053

Question

Response

EXTERIOR

DOORS

DOORS AND FRAMES

Roof Plan reference

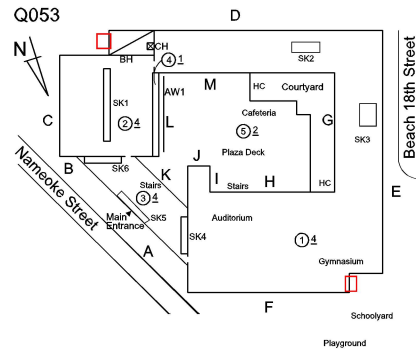

Deficiency Quantity
Quantity Uom
Potential Action
Urgency of Action
Purpose of Action
Deficiency Photo1

2
EACH
REPLACE
PRIORITY 4
LEVEL 2

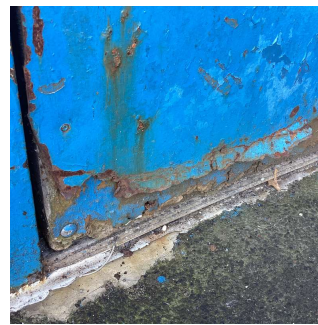

Facade F

Violations

No violations recorded.

Deficiency

METAL: DETERIORATED DOOR AND FRAME - MINOR DETERIORATION

Roof Plan reference

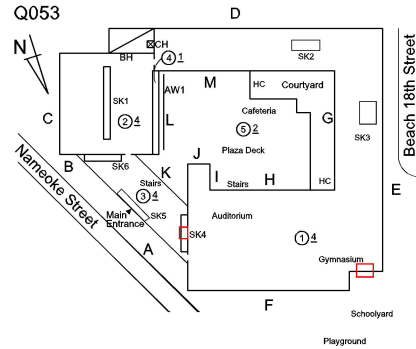

Deficiency Quantity
Quantity Uom
Potential Action
Urgency of Action
Purpose of Action
Deficiency Photo1
Violations

4
EACH
MAINTENANCE
PRIORITY 3
LEVEL 2
No photo recorded
No violations recorded.

Deficiency

METAL: DETERIORATED DOOR AND FRAME - MAJOR DETERIORATION

**NYC Department of Education
Building Condition Assessment Survey 2023 - 2024**

Architectural Inspection

Q053

Question	Response
EXTERIOR	
DOORS	
DOORS AND FRAMES	
Roof Plan reference	
Deficiency Quantity	4
Quantity Uom	EACH
Potential Action	REPLACE
Urgency of Action	PRIORITY 4
Purpose of Action	LEVEL 2
Deficiency Photo1	
Violations	Facade A No violations recorded.
DOOR HARDWARE	Inspected
Condition	3 - Fair
Deficiency	No deficiencies recorded
LINTELS	Inspected
Condition	2 - Between Good and Fair
Deficiency	No deficiencies recorded
TRANSOM/SIDE LIGHT	Inspected
Condition	2 - Between Good and Fair
Deficiency	No deficiencies recorded
EXTERIOR WALLS	Inspected
Material Type(s)	Masonry, Wood
Replacement Quantity	72,000
Replacement Uom	S.F.
Instance on All Facades	Inspected
Instance Condition	3 - Fair
Instance Quantity	72,000
Instance Quantity Uom	S.F.
Deficiency	BRICK: WATER INFILTRATION IN INSTRUCTIONAL SPACE

**NYC Department of Education
Building Condition Assessment Survey 2023 - 2024**

Architectural Inspection

Q053

Question

Response

EXTERIOR

EXTERIOR WALLS

Roof Plan reference

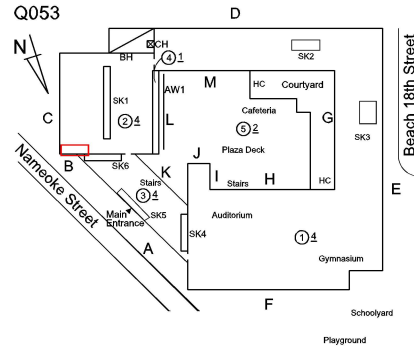

Elevation

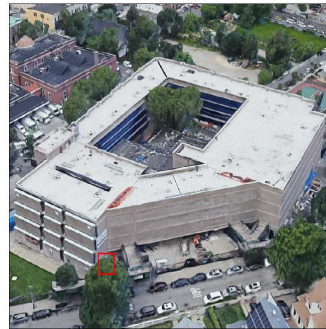

Deficiency Quantity

100

Quantity Uom

S.F.

Potential Action

REPAIR

Urgency of Action

PRIORITY 5

Purpose of Action

LEVEL 2

Deficiency Photo1

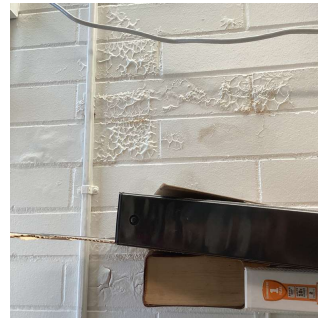

Facade B - Room 102

Violations

No violations recorded.

Deficiency

BRICK: CRACKS/DISPLACED/SPALLED BRICK AT BUILDING CORNERS

Roof Plan reference

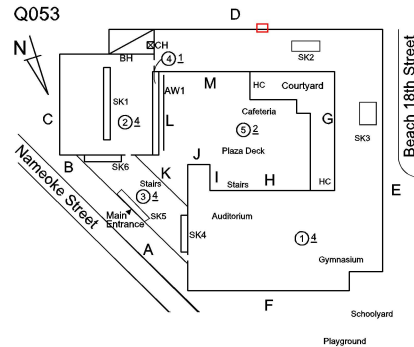

**NYC Department of Education
Building Condition Assessment Survey 2023 - 2024**

Architectural Inspection

Q053

Question

Response

EXTERIOR

EXTERIOR WALLS

Elevation

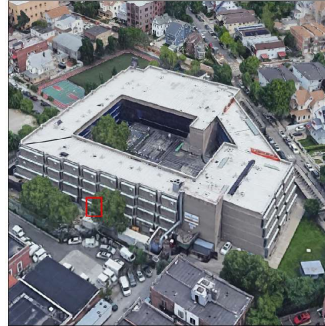

Deficiency Quantity

10

Quantity Uom

S.F.

Potential Action

REMOVE AND REBUILD

Urgency of Action

PRIORITY 4

Purpose of Action

LEVEL 2

Deficiency Photo1



Facade E

Violations

No violations recorded.

Deficiency

BRICK: EFFLORESCENCE

Roof Plan reference

Q053

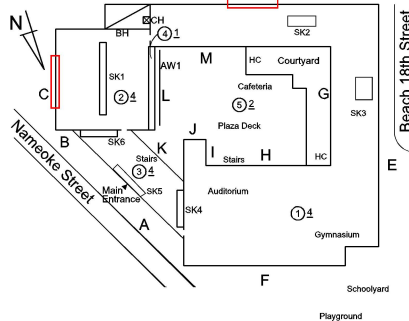

Elevation



Deficiency Quantity

200

Quantity Uom

S.F.

Potential Action

MAINTENANCE

**NYC Department of Education
Building Condition Assessment Survey 2023 - 2024**

Architectural Inspection

Q053

Question

Response

EXTERIOR

EXTERIOR WALLS

Urgency of Action
Purpose of Action
Deficiency Photo1
Violations

PRIORITY 1
LEVEL 1
No photo recorded
No violations recorded.

Deficiency

Roof Plan reference

BRICK: MAJOR / THRU CRACKS

Q053

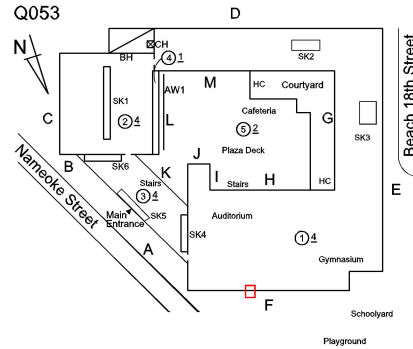

Elevation



Deficiency Quantity
Quantity Uom
Potential Action
Urgency of Action
Purpose of Action
Deficiency Photo1

10
S.F.
REMOVE AND REBUILD
PRIORITY 4
LEVEL 2



Facade F
No violations recorded.

Deficiency

BRICK: DETERIORATED JOINTS

**NYC Department of Education
Building Condition Assessment Survey 2023 - 2024**

Architectural Inspection

Q053

Question

Response

EXTERIOR

EXTERIOR WALLS

Roof Plan reference

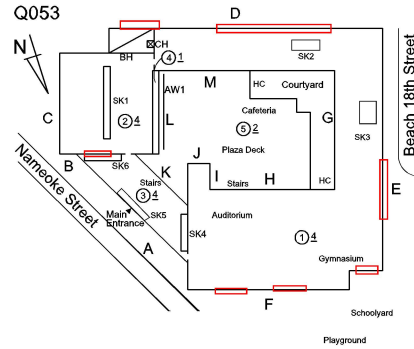

Elevation



Deficiency Quantity
Quantity Uom
Potential Action
Urgency of Action
Purpose of Action
Deficiency Photo1

1,000
S.F.
REPOINT
PRIORITY 3
LEVEL 2



Facade F
No violations recorded.

Violations

EXTERIOR SOFFITS

Inspected

Condition

2 - Between Good and Fair

Deficiency

No deficiencies recorded

LOADING DOCK

Does not Exist

LOUVER

Inspected

Condition

3 - Fair

Deficiency

MAJOR RUSTING

**NYC Department of Education
Building Condition Assessment Survey 2023 - 2024**

Architectural Inspection

Q053

Question

Response

EXTERIOR

LOUVER

Roof Plan reference

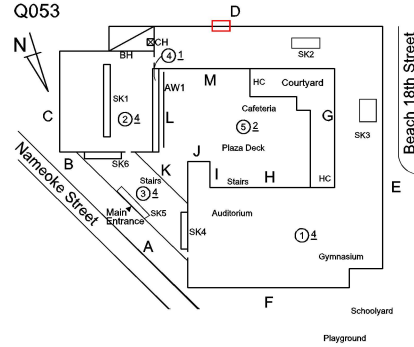

Elevation

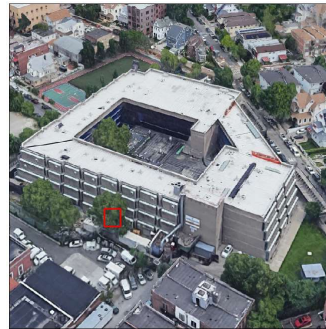

Deficiency Quantity
Quantity Uom
Potential Action
Urgency of Action
Purpose of Action
Deficiency Photo1

10
S.F.
REPLACE
PRIORITY 4
LEVEL 2

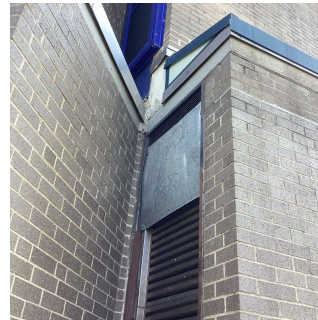

Facade D
No violations recorded.

Violations

PARAPETS

Material Type(s)

Inspected
Masonry

Replacement Quantity

9,000

Replacement Uom

C.F.

Instance on All Facades

Inspected

Instance Condition

1 - Good

Instance Quantity

9,000

Instance Quantity Uom

C.F.

Deficiency

No deficiencies recorded

PLAZA DECK

Inspected

Instance on Pavers: Roof 5

Inspected

Instance Condition

1 - Good

Instance Quantity

10,000

NYC Department of Education
Building Condition Assessment Survey 2023 - 2024

Architectural Inspection

Q053

Question	Response
EXTERIOR	
PLAZA DECK	
Instance Quantity Uom	S.F.
Installation Year	2023
Source of Installation	Custodial Staff
Deficiency	No deficiencies recorded
ROOF	Inspected
Roofing	Inspected
Replacement Quantity	48,500
Replacement Uom	S.F.
ROOF HATCH/SMOKE HATCH	Does not Exist
LEADERS, GUTTERS, DOWNSPOUTS, SCUPPERS	Inspected
Condition	1 - Good
Deficiency	No deficiencies recorded
ROOF BARRIER/FENCE	Inspected
Condition	1 - Good
Deficiency	No deficiencies recorded
ROOF CAGE	Does not Exist
ROOFING	Inspected
Instance on Modified Bitumen: Roofs 1-4	Inspected
Instance Condition	1 - Good
Instance Photo	
	Roof 1
Instance Quantity	48,500
Instance Quantity Uom	S.F.
Does the roof have major mechanical equipment sitting on Dunnage Steel less than 18" above the Roofing?	No
Does this roof instance have a Sustainable Roof System?	Yes
Sustainable Roof Type	White Roof
Sustainable Roof Location (Roof Number)	Roof 1
Do solar panels exist on these roofs?	No
Is/Are the roof(s) suitable for Solar Panel installation?	Yes
Installation Year	2021
Source of Installation	Custodial Staff
Deficiency	No deficiencies recorded
ROOFING DRAINS	Inspected
Condition	3 - Fair
Deficiency	DETERIORATED

**NYC Department of Education
Building Condition Assessment Survey 2023 - 2024**

Architectural Inspection

Q053

Question **Response**

EXTERIOR

ROOF

Roofing

ROOFING DRAINS

Roof Plan reference

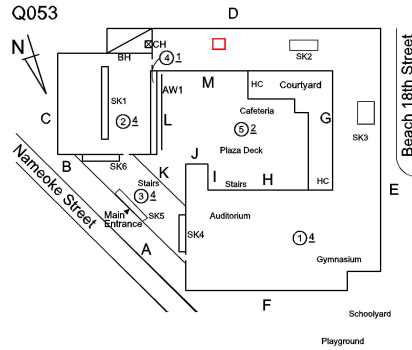

Deficiency Quantity
Quantity Uom
Potential Action
Urgency of Action
Purpose of Action
Deficiency Photo1

1
EACH
REPLACE
PRIORITY 4
LEVEL 2



Roof 1
No violations recorded.

Violations

Specialties

BULKHEAD/PENTHOUSE

Condition

Deficiency

Roof Plan reference

Inspected

Inspected

3 - Fair

BULKHEAD/PENTHOUSE WALLS/EXTERIOR: DETERIORATED JOINTS

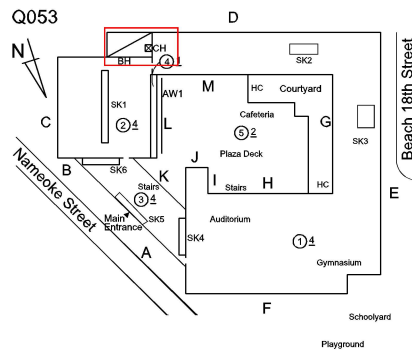

Deficiency Quantity
Quantity Uom
Potential Action
Urgency of Action
Purpose of Action

100
S.F.
REPOINT
PRIORITY 3
LEVEL 2

**NYC Department of Education
Building Condition Assessment Survey 2023 - 2024**

Architectural Inspection

Q053

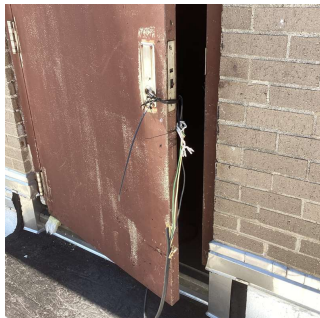
Question	Response
EXTERIOR	
ROOF	
Specialties	
BULKHEAD/PENTHOUSE	
Deficiency Photo1	
Violations	Roof 1 - Bulkhead No violations recorded.
Deficiency	BULKHEAD/PENTHOUSE DOORS: DETERIORATED DOOR
Roof Plan reference	Q053
Deficiency Quantity	1
Quantity Uom	EACH
Potential Action	REPLACE DOOR
Urgency of Action	PRIORITY 3
Purpose of Action	LEVEL 2
Deficiency Photo1	
Violations	Roof 1 - Bulkhead No violations recorded.
CUPOLA/ SPIRES/ TOWERS	Does not Exist
DORMER	Does not Exist
DUNNAGE STEEL	Inspected
Condition	2 - Between Good and Fair
Deficiency	No deficiencies recorded
SKYLIGHT/ROOF VENT	Inspected
Material Type(s)	Glass, Plastic
Condition	3 - Fair

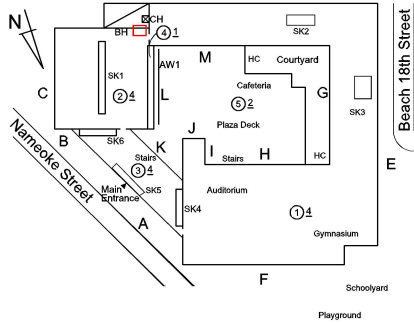

**NYC Department of Education
Building Condition Assessment Survey 2023 - 2024**

Architectural Inspection

Q053

Question

Response

EXTERIOR

ROOF

Specialties

SKYLIGHT/ROOF VENT

Deficiency

Roof Plan reference

WATER INFILTRATION

Q053

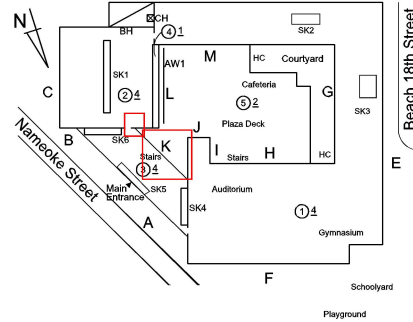

Deficiency Quantity

200

Quantity Uom

S.F.

Potential Action

MAINTENANCE

Urgency of Action

PRIORITY 3

Purpose of Action

LEVEL 2

Deficiency Photo1



Facade K - Skylight at Corridor near Room 381, also Skylight Room 301

Violations

No violations recorded.

Deficiency

Roof Plan reference

DAMAGED GUARDS

Q053

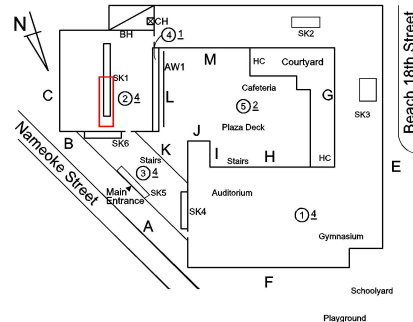

Deficiency Quantity

10

Quantity Uom

S.F.

Potential Action

MAINTENANCE

Urgency of Action

PRIORITY 3

Purpose of Action

LEVEL 2

NYC Department of Education
Building Condition Assessment Survey 2023 - 2024

Architectural Inspection

Q053

Question	Response
EXTERIOR	
ROOF	
Specialties	
SKYLIGHT/ROOF VENT	
Deficiency Photo1	
Violations	Roof 1 - Skylight 1 No violations recorded.
ROOF/GRAVITY TANK	Does not Exist
STAIRS/RAMPS: EXTERIOR	Inspected
BUILDING CHEEK/FLANK WALLS	Does not Exist
RAILINGS	Inspected
Condition	2 - Between Good and Fair
Deficiency	No deficiencies recorded
STAIRS/RAMPS	Inspected
Condition	2 - Between Good and Fair
Deficiency	No deficiencies recorded
WINDOWS	Inspected
Replacement Quantity	20,000
Replacement Uom	S.F.
EXTERIOR GUARDS	Inspected
Condition	1 - Good
Deficiency	No deficiencies recorded
LINTELS	Inspected
Condition	2 - Between Good and Fair
Deficiency	No deficiencies recorded
WINDOWS	Inspected
Material Type(s)	Aluminum
Instance on Aluminum - Double Hung: All Facades	Inspected
Instance Condition	1 - Good
Instance Quantity	2,000
Instance Quantity Uom	S.F.
Are these windows insulated	Yes
Installation Year	2023
Source of Installation	Custodial Staff
Deficiency	No deficiencies recorded
Instance on Aluminum - Other: All Facades	Inspected
Instance Condition	2 - Between Good and Fair
Instance Quantity	18,000
Instance Quantity Uom	S.F.
Are these windows insulated	Yes
Installation Year	2023

**NYC Department of Education
Building Condition Assessment Survey 2023 - 2024**

Architectural Inspection

Q053

Question	Response
EXTERIOR	
WINDOWS	
WINDOWS	
Source of Installation	Custodial Staff
Deficiency	ALUMINUM - OTHER: BROKEN PANE
Roof Plan reference	Q053
	
Elevation	
Deficiency Quantity	150
Quantity Uom	S.F.
Potential Action	MAINTENANCE
Urgency of Action	PRIORITY 3
Purpose of Action	LEVEL 2
Deficiency Photo1	
	Facade M - Cafeteria
Violations	No violations recorded.
INTERIOR	Inspected
POOLS	Does not Exist
STRUCTURAL	Inspected
COLUMNS/BEAMS/BEARING WALLS	Inspected
Condition	2 - Between Good and Fair
Deficiency	No deficiencies recorded
FLOOR STRUCTURE	Inspected
Condition	3 - Fair
Deficiency	CONCRETE SLAB ON GRADE: THRU CRACKS
Deficiency Location/Instance	Basement - Electrical Panel Room

**NYC Department of Education
Building Condition Assessment Survey 2023 - 2024**

Architectural Inspection

Q053

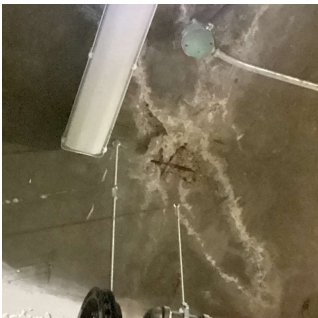
Question	Response
INTERIOR	
STRUCTURAL	
FLOOR STRUCTURE	
Deficiency Quantity	10
Quantity Uom	S.F.
Potential Action	REPAIR
Urgency of Action	PRIORITY 3
Purpose of Action	LEVEL 5
Deficiency Photo1	
	Basement - Electrical Panel Room
Violations	No violations recorded.
Deficiency	CONCRETE: CRACKS/SPALLED/REINFORCEMENT EXPOSED
Deficiency Location/Instance	Basement - Pump Room
Deficiency Quantity	30
Quantity Uom	S.F.
Potential Action	REPAIR
Urgency of Action	PRIORITY 3
Purpose of Action	LEVEL 5
Deficiency Photo1	
	Basement - Pump Room
Violations	No violations recorded.
FOUNDATION WALLS	
	Inspected
Material Type(s)	Concrete
Condition	2 - Between Good and Fair
Deficiency	No deficiencies recorded
ROOF STRUCTURE	
	Inspected
Condition	2 - Between Good and Fair
Deficiency	No deficiencies recorded
VAULTS-BUNKERS	
	Does not Exist
AUDITORIUM	
	Inspected
Instance on 3rd Floor (695 Seats)	Under Construction
CAFETERIA	
	Inspected
Instance on 1st Floor	Inspected
Ceiling	

**NYC Department of Education
Building Condition Assessment Survey 2023 - 2024**

Architectural Inspection

Q053

Question	Response
----------	----------

INTERIOR

CAFETERIA

Ceiling

Instance on 1st Floor	Inspected
Condition	2 - Between Good and Fair
Deficiency	PLASTER: CRACKS/SPALLING
Deficiency Location/Instance	Near Room 170
Deficiency Quantity	20
Quantity Uom	S.F.
Potential Action	REPLACE
Urgency of Action	PRIORITY 3
Purpose of Action	LEVEL 2
Deficiency Photo1	



Near Room 170
No violations recorded.

Violations

Door(s)

Instance on 1st Floor	Inspected
Condition	4 - Between Fair and Poor
Deficiency	WOOD: DETERIORATED DOOR
Deficiency Location/Instance	Entrances
Deficiency Quantity	2
Quantity Uom	EACH
Potential Action	MAINTENANCE
Urgency of Action	PRIORITY 3
Purpose of Action	LEVEL 2
Deficiency Photo1	



Entrance
No violations recorded.

Violations

Fixed Equipment

Instance on 1st Floor	Does not Exist
-----------------------	----------------

Floor Finish

Instance on 1st Floor	Inspected
Condition	2 - Between Good and Fair
Deficiency	VINYL TILES: BROKEN/DETERIORATED/MISSING TILES

**NYC Department of Education
Building Condition Assessment Survey 2023 - 2024**

Architectural Inspection

Q053

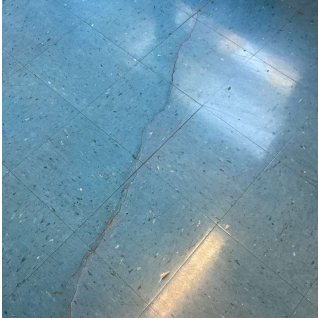
Question	Response
INTERIOR	
CAFETERIA	
Floor Finish	
Deficiency Location/Instance	Near Entrance, Serving Area, Windows
Deficiency Quantity	40
Quantity Uom	S.F.
Potential Action	REPLACE
Urgency of Action	PRIORITY 3
Purpose of Action	LEVEL 2
Deficiency Photo1	
Violations	Near Entrance No violations recorded.
Sliding-folding Partition	
Instance on 1st Floor	Does not Exist
Stage	
Instance on 1st Floor	Does not Exist
Walls	
Instance on 1st Floor	Inspected
Condition	2 - Between Good and Fair
Deficiency	WOOD PANELING: DETERIORATED
Deficiency Location/Instance	Near center
Deficiency Quantity	10
Quantity Uom	S.F.
Potential Action	REPLACE
Urgency of Action	PRIORITY 3
Purpose of Action	LEVEL 2
Deficiency Photo1	
Violations	Near center No violations recorded.
Deficiency	PLASTER: CRACKS/SPALLING
Deficiency Location/Instance	Columns, Near Room 170
Deficiency Quantity	20
Quantity Uom	S.F.
Potential Action	REPLACE

**NYC Department of Education
Building Condition Assessment Survey 2023 - 2024**

Architectural Inspection



Q053

Question	Response
INTERIOR	
CAFETERIA	
Walls	
Urgency of Action	PRIORITY 3
Purpose of Action	LEVEL 2
Deficiency Photo1	
	Near Room 170
Violations	No violations recorded.
Window Curtains/Shades/Blinds	
Instance on 1st Floor	Does not Exist
CLASSROOMS/CORRIDORS/ADMIN SPACES	
Ceiling	Inspected
Condition	2 - Between Good and Fair
Deficiency	GYPSUM BOARD: DAMAGED/DETERIORATED - ACTIVE LEAK
Deficiency Location/Instance	Corridor Near Room 189
Deficiency Quantity	30
Quantity Uom	S.F.
Potential Action	REPLACE
Urgency of Action	PRIORITY 5
Purpose of Action	LEVEL 2
Deficiency Photo1	
	Corridor Near Room 189
Violations	No violations recorded.
Deficiency	PLASTER: CRACKS/SPALLING
Deficiency Location/Instance	Rooms 353, 419
Deficiency Quantity	40
Quantity Uom	S.F.
Potential Action	REPLACE
Urgency of Action	PRIORITY 3
Purpose of Action	LEVEL 2

**NYC Department of Education
Building Condition Assessment Survey 2023 - 2024**

Architectural Inspection

Q053

Question	Response
INTERIOR	
CLASSROOMS/CORRIDORS/ADMIN SPACES	
Ceiling	
Deficiency Photo1	
	Room 353
Violations	No violations recorded.
Door(s)	
Condition	Inspected
	5 - Poor
Deficiency	WOOD: DETERIORATED DOOR
Deficiency Location/Instance	Rooms 109, 110, 357, 423, 477, and others
Deficiency Quantity	25
Quantity Uom	EACH
Potential Action	MAINTENANCE
Urgency of Action	PRIORITY 3
Purpose of Action	LEVEL 2
Deficiency Photo1	
	Room 110
Violations	No violations recorded.
Floor Finish	
Condition	Inspected
	2 - Between Good and Fair
Deficiency	TERRAZZO: CRACKS
Deficiency Location/Instance	Main Entrance Lobby, Corridor near Rooms 187, 239, Cafeteria, Gymnasium, and others
Deficiency Quantity	330
Quantity Uom	S.F.
Potential Action	REPLACE
Urgency of Action	PRIORITY 3
Purpose of Action	LEVEL 2

**NYC Department of Education
Building Condition Assessment Survey 2023 - 2024**

Architectural Inspection

Q053

Question	Response
----------	----------

INTERIOR

CLASSROOMS/CORRIDORS/ADMIN SPACES

Floor Finish

Deficiency Photo1

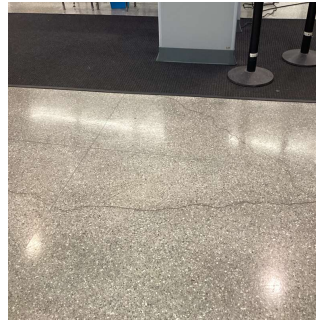

Main Entrance Lobby

Violations

No violations recorded.

Deficiency

VINYL TILES: BROKEN/DETERIORATED/MISSING TILES

Deficiency Location/Instance

Room 368, Exit 1, Corridor near Rooms 239, 312

Deficiency Quantity

100

Quantity Uom

S.F.

Potential Action

REPLACE

Urgency of Action

PRIORITY 3

Purpose of Action

LEVEL 2

Deficiency Photo1



Room 368

Violations

No violations recorded.

Walls

Inspected

Condition

2 - Between Good and Fair

Deficiency

PLASTER: CRACKS/SPALLING

Deficiency Location/Instance

Room 124, Corridor near Rooms 408, 427

Deficiency Quantity

40

Quantity Uom

S.F.

Potential Action

REPLACE

Urgency of Action

PRIORITY 3

Purpose of Action

LEVEL 2

Deficiency Photo1

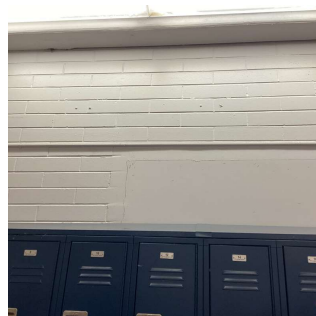

NYC Department of Education
Building Condition Assessment Survey 2023 - 2024

Architectural Inspection



Q053

Question	Response
INTERIOR	
CLASSROOMS/CORRIDORS/ADMIN SPACES	
Walls	Inspected
	Room 124
Violations	No violations recorded.
Specialties	Inspected
Classroom Locker(s)	Inspected
Condition	2 - Between Good and Fair
Deficiency	No deficiencies recorded
Fixed Seating	Does not Exist
GYMNASIUM	Inspected
Instance on 1st Floor	Inspected
Ceiling	
Instance on 1st Floor	Inspected
Condition	2 - Between Good and Fair
Deficiency	No deficiencies recorded
Door(s)	
Instance on 1st Floor	Inspected
Condition	5 - Poor
Deficiency	WOOD: DETERIORATED DOOR
Deficiency Location/Instance	Storage Room, Office/ Storage Room
Deficiency Quantity	4
Quantity Uom	EACH
Potential Action	MAINTENANCE
Urgency of Action	PRIORITY 3
Purpose of Action	LEVEL 2
Deficiency Photo1	
	Storage Room
Violations	No violations recorded.
Fixed Equipment	
Instance on 1st Floor	Inspected
Condition	2 - Between Good and Fair
Deficiency	No deficiencies recorded
Floor Finish	
Instance on 1st Floor	Inspected
Condition	2 - Between Good and Fair
Deficiency	CONCRETE: CRACKS
Deficiency Location/Instance	Office/Storage
Deficiency Quantity	30
Quantity Uom	S.F.
Potential Action	REPLACE
Urgency of Action	PRIORITY 3

**NYC Department of Education
Building Condition Assessment Survey 2023 - 2024**

Architectural Inspection

Q053

Question	Response
INTERIOR	
GYMNASIUM	
Floor Finish	
Purpose of Action	LEVEL 2
Deficiency Photo1	
Violations	Office/Storage No violations recorded.
Seating	
Instance on 1st Floor	Does not Exist
Sliding-folding Partition	
Instance on 1st Floor	Inspected
Condition	2 - Between Good and Fair
Deficiency	No deficiencies recorded
Stage	
Instance on 1st Floor	Does not Exist
Walls	
Instance on 1st Floor	Inspected
Condition	2 - Between Good and Fair
Deficiency	WALL PADDING: DETERIORATED
Deficiency Location/Instance	Near Center
Deficiency Quantity	100
Quantity Uom	S.F.
Potential Action	REPLACE
Urgency of Action	PRIORITY 3
Purpose of Action	LEVEL 2
Deficiency Photo1	
Violations	Near Center No violations recorded.
Deficiency	MASONRY: CRACKS/SPALLING
Deficiency Location/Instance	Storage Room
Deficiency Quantity	10
Quantity Uom	S.F.
Potential Action	REPLACE
Urgency of Action	PRIORITY 3

**NYC Department of Education
Building Condition Assessment Survey 2023 - 2024**

Architectural Inspection

Q053

Question	Response
INTERIOR	
GYMNASIUM	
Walls	
Purpose of Action	LEVEL 2
Deficiency Photo1	
Violations	Storage Room No violations recorded.
Window Curtains/Shades/Blinds	
Instance on 1st Floor	Does not Exist
INTERIOR DOOR HARDWARE	
Condition	Inspected 3 - Fair
Deficiency	No deficiencies recorded
INTERIOR GUARDS	
Condition	Inspected 2 - Between Good and Fair
Deficiency	No deficiencies recorded
KITCHEN	
Instance on 1st Floor	Inspected
Ceiling	
Instance on 1st Floor	Inspected
Condition	2 - Between Good and Fair
Deficiency	No deficiencies recorded
Door(s)	
Instance on 1st Floor	Inspected
Condition	3 - Fair
Deficiency	METAL: DETERIORATED DOOR
Deficiency Location/Instance	Serving Area
Deficiency Quantity	1
Quantity Uom	EACH
Potential Action	MAINTENANCE
Urgency of Action	PRIORITY 3
Purpose of Action	LEVEL 2
Deficiency Photo1	
Violations	Serving Area No violations recorded.

**NYC Department of Education
Building Condition Assessment Survey 2023 - 2024**

Architectural Inspection

Q053

Question	Response
INTERIOR	
KITCHEN	
Floor Finish	
Instance on 1st Floor	Inspected
Condition	3 - Fair
Deficiency	QUARRY TILE: BROKEN/MISSING TILES
Deficiency Location/Instance	Near center
Deficiency Quantity	10
Quantity Uom	S.F.
Potential Action	REPLACE
Urgency of Action	PRIORITY 5
Purpose of Action	LEVEL 6
Deficiency Photo1	
Violations	Near center No violations recorded.
Deficiency	QUARRY TILE: BROKEN/MISSING TILES
Deficiency Location/Instance	Near Room 128, Center, Serving Area
Deficiency Quantity	20
Quantity Uom	S.F.
Potential Action	REPLACE
Urgency of Action	PRIORITY 3
Purpose of Action	LEVEL 2
Deficiency Photo1	
Violations	Near Room 128 No violations recorded.
Deficiency	CONCRETE: CRACKS
Deficiency Location/Instance	Room 128, Mop Room
Deficiency Quantity	40
Quantity Uom	S.F.
Potential Action	REPLACE
Urgency of Action	PRIORITY 3
Purpose of Action	LEVEL 2

**NYC Department of Education
Building Condition Assessment Survey 2023 - 2024**

Architectural Inspection

Q053

Question	Response
INTERIOR	
KITCHEN	
Floor Finish	
Deficiency Photo1	
Violations	Room 128 No violations recorded.
Walls	
Instance on 1st Floor	Inspected
Condition	2 - Between Good and Fair
Deficiency	BRICK: CRACKS/SPALLING
Deficiency Location/Instance	Near Room 124
Deficiency Quantity	10
Quantity Uom	S.F.
Potential Action	REPLACE
Urgency of Action	PRIORITY 3
Purpose of Action	LEVEL 2
Deficiency Photo1	
Violations	Near Room 124 No violations recorded.
LIBRARY	
Instance on Room 347	Inspected
Built-in Furnishing	
Instance on Room 347	Inspected
Condition	2 - Between Good and Fair
Deficiency	No deficiencies recorded
Ceiling	
Instance on Room 347	Inspected
Condition	2 - Between Good and Fair
Deficiency	No deficiencies recorded
Door(s)	
Instance on Room 347	Inspected
Condition	4 - Between Fair and Poor
Deficiency	WOOD: DETERIORATED DOOR
Deficiency Location/Instance	Entrances

**NYC Department of Education
Building Condition Assessment Survey 2023 - 2024**

Architectural Inspection

Q053

Question	Response
----------	----------

INTERIOR

LIBRARY

Door(s)

Deficiency Quantity	2
Quantity Uom	EACH
Potential Action	MAINTENANCE
Urgency of Action	PRIORITY 3
Purpose of Action	LEVEL 2
Deficiency Photo1	



Entrance

Violations No violations recorded.

Floor Finish

Instance on Room 347	Inspected
Condition	2 - Between Good and Fair
Deficiency	VINYL TILES: BROKEN/DETERIORATED/MISSING TILES
Deficiency Location/Instance	Computer Room
Deficiency Quantity	10
Quantity Uom	S.F.
Potential Action	REPLACE
Urgency of Action	PRIORITY 3
Purpose of Action	LEVEL 2
Deficiency Photo1	



Computer Room

Violations No violations recorded.

Walls

Instance on Room 347	Inspected
Condition	2 - Between Good and Fair
Deficiency	BRICK: CRACKS/SPALLING
Deficiency Location/Instance	Conference Room
Deficiency Quantity	20
Quantity Uom	S.F.
Potential Action	REPLACE
Urgency of Action	PRIORITY 3
Purpose of Action	LEVEL 2

**NYC Department of Education
Building Condition Assessment Survey 2023 - 2024**

Architectural Inspection



Q053

Question	Response
INTERIOR	
LIBRARY	
Walls	
Deficiency Photo1	
	Conference Room
Violations	No violations recorded.
Deficiency	PLASTER: CRACKS/SPALLING
Deficiency Location/Instance	Near Librarian Desk
Deficiency Quantity	10
Quantity Uom	S.F.
Potential Action	REPLACE
Urgency of Action	PRIORITY 3
Purpose of Action	LEVEL 2
Deficiency Photo1	
	Near Librarian Desk
Violations	No violations recorded.
LOCKER ROOM	Does not Exist
MULTI-PURPOSE ROOM	Does not Exist
SCIENCE DEMO ROOM	Does not Exist
SCIENCE LAB	Inspected
Instance on Room 279	Inspected
Alternative use	No
Instance on Room 408	Inspected
Alternative use	No
Fixed Equipment	
Instance on Room 279	Inspected
Condition	3 - Fair
Deficiency	CABINETRY: MISSING/DAMAGED
Deficiency Location/Instance	Room 279
Deficiency Quantity	10
Quantity Uom	L.F.
Potential Action	REPLACE
Urgency of Action	PRIORITY 3

**NYC Department of Education
Building Condition Assessment Survey 2023 - 2024**

Architectural Inspection

Q053

Question	Response
INTERIOR	
SCIENCE LAB	
Fixed Equipment	
Purpose of Action	LEVEL 2
Deficiency Photo1	
	Room 279
Violations	No violations recorded.
SCIENCE PREP ROOM	
	Inspected
Instance on Room 279A	Inspected
Alternative use	No
Instance on Room 414	Inspected
Alternative use	Yes
Fixed Equipment	
Instance on Room 279A	Inspected
Condition	2 - Between Good and Fair
Deficiency	No deficiencies recorded
Instance on Room 414	Inspected
Condition	2 - Between Good and Fair
Deficiency	No deficiencies recorded
SHOWER ROOM	
	Does not Exist
STAIRS/RAMPS: INTERIOR	
	Inspected
Do Letter Stair Signs Exist?	Yes
Ceiling	
	Inspected
Condition	2 - Between Good and Fair
Deficiency	PLASTER: CRACKS/SPALLING
Deficiency Location/Instance	Stair D/4
Deficiency Quantity	10
Quantity Uom	S.F.
Potential Action	REPLACE
Urgency of Action	PRIORITY 3
Purpose of Action	LEVEL 2
Deficiency Photo1	
	Stair D/4
Violations	No violations recorded.

NYC Department of Education
Building Condition Assessment Survey 2023 - 2024

Architectural Inspection

Q053

Question	Response
INTERIOR	
STAIRS/RAMPS: INTERIOR	
Door(s)	Inspected
Condition	5 - Poor
Deficiency	METAL: DETERIORATED DOOR AND FRAME
Deficiency Location/Instance	Stairs A/2, E/Vestibule, 4
Deficiency Quantity	6
Quantity Uom	EACH
Potential Action	MAINTENANCE
Urgency of Action	PRIORITY 3
Purpose of Action	LEVEL 2
Deficiency Photo1	
Violations	Stair E/Vestibule No violations recorded.
Deficiency	METAL: DETERIORATED DOOR
Deficiency Location/Instance	Stair B/Vestibule, 2
Deficiency Quantity	2
Quantity Uom	EACH
Potential Action	MAINTENANCE
Urgency of Action	PRIORITY 3
Purpose of Action	LEVEL 2
Deficiency Photo1	
Violations	Stair B/Vestibule No violations recorded.
Partition	Does not Exist
Railings	Inspected
Condition	3 - Fair
Deficiency	METAL: DAMAGED
Deficiency Location/Instance	Stair E/1
Deficiency Quantity	10
Quantity Uom	L.F.
Potential Action	REPLACE
Urgency of Action	PRIORITY 3
Purpose of Action	LEVEL 2

**NYC Department of Education
Building Condition Assessment Survey 2023 - 2024**

Architectural Inspection

Q053

Question	Response
----------	----------

INTERIOR

STAIRS/RAMPS: INTERIOR

Railings

Deficiency Photo1



Stair E/1

Violations

No violations recorded.

Stairs and Landings

Inspected

Condition

2 - Between Good and Fair

Deficiency

CONCRETE: CRACKS/SPALLING - MAJOR

Deficiency Location/Instance

Stairs B/Vestibule, 2, D/1, E/1

Deficiency Quantity

60

Quantity Uom

S.F.

Potential Action

REPLACE

Urgency of Action

PRIORITY 3

Purpose of Action

LEVEL 2

Deficiency Photo1



Stair E/1

Violations

No violations recorded.

Walls

Inspected

Condition

2 - Between Good and Fair

Deficiency

PLASTER: CRACKS/SPALLING

Deficiency Location/Instance

Stair A/1

Deficiency Quantity

10

Quantity Uom

S.F.

Potential Action

REPLACE

Urgency of Action

PRIORITY 3

Purpose of Action

LEVEL 2

**NYC Department of Education
Building Condition Assessment Survey 2023 - 2024**

Architectural Inspection

Q053

Question	Response
----------	----------

INTERIOR

STAIRS/RAMPS: INTERIOR

Walls

Deficiency Photo1

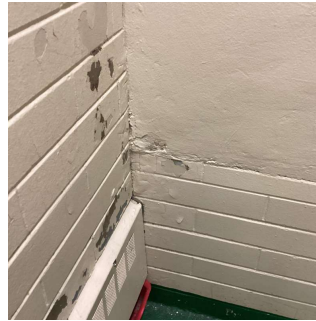

Stair A/1

Violations

No violations recorded.

Deficiency

BRICK: CRACKS/SPALLING

Deficiency Location/Instance

Stair C/1, E/Vestibule

Deficiency Quantity

10

Quantity Uom

S.F.

Potential Action

REPLACE

Urgency of Action

PRIORITY 3

Purpose of Action

LEVEL 2

Deficiency Photo1

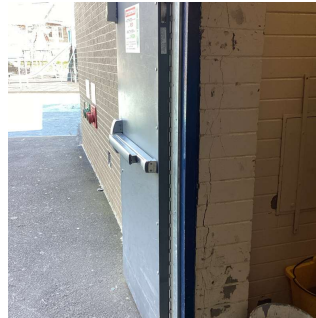

Stair E/Vestibule

Violations

No violations recorded.

TOILET ROOMS - STAFF

Inspected

Ceiling

Inspected

Condition

2 - Between Good and Fair

Deficiency

GYPSUM BOARD: DAMAGED/DETERIORATED

Deficiency Location/Instance

Room 187

Deficiency Quantity

10

Quantity Uom

S.F.

Potential Action

REPLACE

Urgency of Action

PRIORITY 3

Purpose of Action

LEVEL 2

**NYC Department of Education
Building Condition Assessment Survey 2023 - 2024**

Architectural Inspection

Q053

Question	Response
INTERIOR	
TOILET ROOMS - STAFF	
Ceiling	Inspected
Deficiency Photo1	
	Room 187
Violations	No violations recorded.
Door(s)	Inspected
Condition	5 - Poor
Deficiency	WOOD: DETERIORATED DOOR
Deficiency Location/Instance	Rooms 123, 187, 189, Inside Nurse Room
Deficiency Quantity	4
Quantity Uom	EACH
Potential Action	MAINTENANCE
Urgency of Action	PRIORITY 3
Purpose of Action	LEVEL 2
Deficiency Photo1	
	Room 189
Violations	No violations recorded.
Floor Finish	Inspected
Condition	2 - Between Good and Fair
Deficiency	No deficiencies recorded
Stalls	Inspected
Condition	4 - Between Fair and Poor
Deficiency	RUST - MAJOR
Deficiency Location/Instance	Inside Kitchen
Deficiency Quantity	1
Quantity Uom	EACH
Potential Action	REPLACE
Urgency of Action	PRIORITY 3
Purpose of Action	LEVEL 2

**NYC Department of Education
Building Condition Assessment Survey 2023 - 2024**

Architectural Inspection

Q053

Question	Response
----------	----------

INTERIOR

TOILET ROOMS - STAFF

Stalls

Deficiency Photo1



Inside Kitchen

No violations recorded.

Violations

Walls

Inspected

Condition

2 - Between Good and Fair

Deficiency

PLASTER: CRACKS/SPALLING

Deficiency Location/Instance

Room 301

Deficiency Quantity

50

Quantity Uom

S.F.

Potential Action

REPLACE

Urgency of Action

PRIORITY 3

Purpose of Action

LEVEL 2

Deficiency Photo1



Room 301

No violations recorded.

Violations

Deficiency

CERAMIC TILE: BROKEN/ MISSING

Deficiency Location/Instance

Room 402

Deficiency Quantity

10

Quantity Uom

S.F.

Potential Action

REPLACE

Urgency of Action

PRIORITY 3

Purpose of Action

LEVEL 2

Deficiency Photo1



NYC Department of Education
Building Condition Assessment Survey 2023 - 2024

Architectural Inspection

Q053

Question	Response
INTERIOR	
TOILET ROOMS - STAFF	Inspected
Walls	Inspected
	Room 402
Violations	No violations recorded.
TOILET ROOMS - STUDENTS	Inspected
Ceiling	Inspected
Condition	2 - Between Good and Fair
Deficiency	GYPSUM BOARD: DAMAGED/DETERIORATED
Deficiency Location/Instance	Room 410
Deficiency Quantity	10
Quantity Uom	S.F.
Potential Action	REPLACE
Urgency of Action	PRIORITY 3
Purpose of Action	LEVEL 2
Deficiency Photo1	
	Room 410
Violations	No violations recorded.
Door(s)	Inspected
Condition	5 - Poor
Deficiency	WOOD: DETERIORATED DOOR
Deficiency Location/Instance	Rooms 135, 149, 172, 179
Deficiency Quantity	4
Quantity Uom	EACH
Potential Action	MAINTENANCE
Urgency of Action	PRIORITY 3
Purpose of Action	LEVEL 2
Deficiency Photo1	
	Room 149
Violations	No violations recorded.
Floor Finish	Inspected
Condition	2 - Between Good and Fair
Deficiency	No deficiencies recorded
Stalls	Inspected

**NYC Department of Education
Building Condition Assessment Survey 2023 - 2024**

Architectural Inspection



Q053

Question	Response
INTERIOR	
TOILET ROOMS - STUDENTS	Inspected
Stalls	Inspected
Condition	2 - Between Good and Fair
Deficiency	No deficiencies recorded
Walls	Inspected
Condition	2 - Between Good and Fair
Deficiency	No deficiencies recorded
LIFE SAFETY	Inspected
F.D. HOLDING AREA	Inspected
Condition	5 - Poor
Deficiency	HOLDING AREAS NOT IDENTIFIED
Deficiency Location/Instance	Corner of Facade E and Facade F - Rooms 147, 247A, 347, 447A
Deficiency Quantity	4
Quantity Uom	EACH
Potential Action	PROVIDE IDENTIFICATION ON EXTERIOR SIDE OF WINDOW
Urgency of Action	PRIORITY 5
Purpose of Action	LEVEL 2
Deficiency Photo1	
Violations	Corner of Facade E and Facade F - Rooms 147, 247A, 347, 447A No violations recorded.
Deficiency	HOLDING AREAS NOT IDENTIFIED
Deficiency Location/Instance	Rooms 147, 247A, 347, 447A
Deficiency Quantity	4
Quantity Uom	EACH
Potential Action	PROVIDE IDENTIFICATION AT DOOR
Urgency of Action	PRIORITY 5
Purpose of Action	LEVEL 2
Deficiency Photo1	
Violations	Room 347 No violations recorded.
STEEL STAIRS	Does not Exist
SITE	Inspected
CONTAINERIZATION	Inspected

**NYC Department of Education
Building Condition Assessment Survey 2023 - 2024**

Architectural Inspection

Q053

Question	Response
SITE	
CONTAINERIZATION	
Condition	5 - Poor
Deficiency	CONTAINER DAMAGED
Deficiency Location/Instance	Near Exit 2
Deficiency Quantity	4
Quantity Uom	EACH
Potential Action	REPLACE
Urgency of Action	PRIORITY 3
Purpose of Action	LEVEL 2
Deficiency Photo1	
Violations	Near Exit 2 No violations recorded.
Drainage System for Asphalt	Inspected
Catch Basins/Manhole - Surrounded by asphalt	Inspected
Condition	2 - Between Good and Fair
Deficiency	No deficiencies recorded
Culverts - Asphalt Covering	Does not Exist
Drainage System for Concrete	Inspected
Catch Basins/Manhole - Surrounded by concrete	Inspected
Condition	4 - Between Fair and Poor
Deficiency	DAMAGED COVER
Deficiency Location/Instance	Near Main Entrance
Deficiency Quantity	2
Quantity Uom	EACH
Potential Action	REPLACE
Urgency of Action	PRIORITY 3
Purpose of Action	LEVEL 2
Deficiency Photo1	
Violations	Near Main Entrance No violations recorded.
Culverts - Concrete Covering	Does not Exist
Drainage System for Soil	Inspected

NYC Department of Education
Building Condition Assessment Survey 2023 - 2024

Architectural Inspection

Q053

Question	Response
SITE	
Drainage System for Soil	Inspected
Catch Basins/Manhole - Surrounded by Soil	Inspected
Condition	2 - Between Good and Fair
Deficiency	No deficiencies recorded
Culverts - Soil Covering	Does not Exist
DRINKING FOUNTAINS	Under Construction
FENCES	Inspected
Condition	4 - Between Fair and Poor
Deficiency	WROUGHT IRON: DAMAGED/DETERIORATED
Deficiency Location/Instance	Beach 18th Street, Nameoke Street
Deficiency Quantity	200
Quantity Uom	S.F.
Potential Action	REPLACE
Urgency of Action	PRIORITY 5
Purpose of Action	LEVEL 6
Deficiency Photo1	
Violations	Beach 18th Street No violations recorded.
Deficiency	CHAIN LINK: RUST - MAJOR
Deficiency Location/Instance	Near Neighbors Limits, Nameoke Street
Deficiency Quantity	2,400
Quantity Uom	S.F.
Potential Action	REPLACE
Urgency of Action	PRIORITY 3
Purpose of Action	LEVEL 2
Deficiency Photo1	
Violations	Near Neighbors Limits No violations recorded.
Deficiency	CHAIN LINK: DAMAGED POST/RAIL
Deficiency Location/Instance	Bayport Place
Deficiency Quantity	10
Quantity Uom	L.F.
Potential Action	REPLACE

**NYC Department of Education
Building Condition Assessment Survey 2023 - 2024**

Architectural Inspection

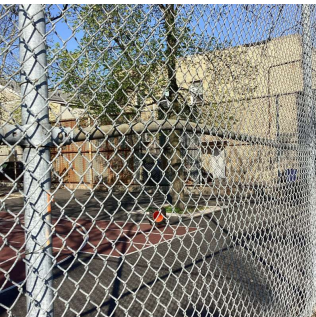
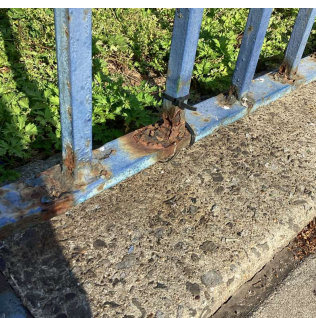

Q053

Question	Response
SITE	
FENCES	
Urgency of Action	PRIORITY 3
Purpose of Action	LEVEL 2
Deficiency Photo1	
	Bayport Place
Violations	No violations recorded.
Deficiency	WROUGHT IRON: RUST - MAJOR
Deficiency Location/Instance	Nameoke Street
Deficiency Quantity	80
Quantity Uom	S.F.
Potential Action	REPLACE
Urgency of Action	PRIORITY 3
Purpose of Action	LEVEL 2
Deficiency Photo1	
	Nameoke Street
Violations	No violations recorded.
Deficiency	WROUGHT IRON: DAMAGED/DETERIORATED
Deficiency Location/Instance	Nameoke Street, Beach 18th Street
Deficiency Quantity	760
Quantity Uom	S.F.
Potential Action	REPLACE
Urgency of Action	PRIORITY 3
Purpose of Action	LEVEL 2
Deficiency Photo1	
	Nameoke Street

NYC Department of Education
Building Condition Assessment Survey 2023 - 2024

Architectural Inspection

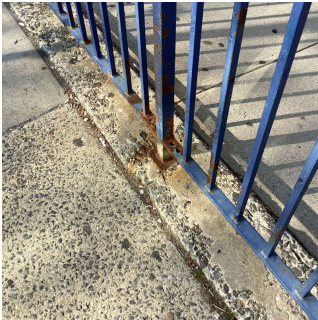
Q053

Question	Response
SITE	
FENCES	
Violations	No violations recorded.
Deficiency	CONCRETE CURB: DAMAGED/DETERIORATED
Deficiency Location/Instance	Nameoke Street, Beach 18th Street, Bayport Place
Deficiency Quantity	190
Quantity Uom	S.F.
Potential Action	REPLACE
Urgency of Action	PRIORITY 3
Purpose of Action	LEVEL 2
Deficiency Photo1	
Violations	Nameoke Street No violations recorded.
Deficiency	CHAIN LINK: DAMAGED/DETERIORATED
Deficiency Location/Instance	Nameoke Street, Bayport Place
Deficiency Quantity	150
Quantity Uom	S.F.
Potential Action	REPLACE
Urgency of Action	PRIORITY 3
Purpose of Action	LEVEL 2
Deficiency Photo1	
Violations	Bayport Place No violations recorded.
IRRIGATION SYSTEM	Does not Exist
PAVING	Inspected
Student Non-Use	Inspected
Gravel Exists?	No
Asphalt	Inspected
Condition	4 - Between Fair and Poor
Deficiency	CRACKS - MAJOR
Deficiency Location/Instance	Near Exit 2, containerization Area
Deficiency Quantity	500
Quantity Uom	S.F.

**NYC Department of Education
Building Condition Assessment Survey 2023 - 2024**

Architectural Inspection



Q053

Question	Response
SITE	
PAVING	
Student Non-Use	
Asphalt	
Potential Action	REPLACE
Urgency of Action	PRIORITY 3
Purpose of Action	LEVEL 2
Deficiency Photo1	
	Near Exit 2
Violations	No violations recorded.
Concrete	Inspected
Condition	3 - Fair
Deficiency	DAMAGED/DETERIORATED/MISSING SECTIONS
Deficiency Location/Instance	Near Exit 2, Containerization Area
Deficiency Quantity	150
Quantity Uom	S.F.
Potential Action	REPLACE
Urgency of Action	PRIORITY 3
Purpose of Action	LEVEL 2
Deficiency Photo1	
	Near Exit 2
Violations	No violations recorded.
Pavers	Does not Exist
Student Use	Inspected
Gravel Exists?	No
Asphalt	Inspected
Condition	4 - Between Fair and Poor
Deficiency	HEAVING
Deficiency Location/Instance	Playground Perimeter , Neighbors Limits
Deficiency Quantity	100
Quantity Uom	S.F.
Potential Action	REPLACE
Urgency of Action	PRIORITY 5
Purpose of Action	LEVEL 6

**NYC Department of Education
Building Condition Assessment Survey 2023 - 2024**

Architectural Inspection

Q053

Question	Response
SITE	
PAVING	
Student Use	
Asphalt	
Deficiency Photo1	
Violations	Near Playground No violations recorded.
Deficiency	CRACKS - MAJOR
Deficiency Location/Instance	Near Playground, Playing Field, basketball Court, School Entrance, Exit 5, Center, and others
Deficiency Quantity	2,500
Quantity Uom	S.F.
Potential Action	REPLACE
Urgency of Action	PRIORITY 3
Purpose of Action	LEVEL 2
Deficiency Photo1	
Violations	Near Playground No violations recorded.
Concrete	Inspected
Condition	3 - Fair
Deficiency	DAMAGED/DETERIORATED/MISSING SECTIONS
Deficiency Location/Instance	Courtyard
Deficiency Quantity	200
Quantity Uom	S.F.
Potential Action	REPLACE
Urgency of Action	PRIORITY 3
Purpose of Action	LEVEL 2

**NYC Department of Education
Building Condition Assessment Survey 2023 - 2024**

Architectural Inspection

Q053

Question	Response
----------	----------

SITE

PAVING

Student Use

Concrete

Deficiency Photo1

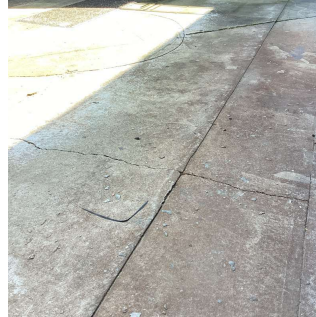

Courtyard

Violations

No violations recorded.

Pavers

Inspected

Condition

2 - Between Good and Fair

Deficiency

DAMAGED/MISSING

Deficiency Location/Instance

Near Exit 5

Deficiency Quantity

10

Quantity Uom

S.F.

Potential Action

REPLACE

Urgency of Action

PRIORITY 3

Purpose of Action

LEVEL 2

Deficiency Photo1



Near Exit 5

Violations

No violations recorded.

Site Sidewalks & Walkways

Inspected

Asphalt

Inspected

Condition

4 - Between Fair and Poor

Deficiency

CRACKS - MAJOR

Deficiency Location/Instance

Near Beach 18th Street

Deficiency Quantity

500

Quantity Uom

S.F.

Potential Action

REPLACE

Urgency of Action

PRIORITY 3



Purpose of Action

LEVEL 2

**NYC Department of Education
Building Condition Assessment Survey 2023 - 2024**

Architectural Inspection

Q053

Question	Response
SITE	
PAVING	
Site Sidewalks & Walkways	
Asphalt	
Deficiency Photo1	
Violations	Near Beach 18th Street No violations recorded.
Concrete	Inspected
Condition	4 - Between Fair and Poor
Deficiency	DAMAGED CURBS
Deficiency Location/Instance	Containerization Area
Deficiency Quantity	50
Quantity Uom	L.F.
Potential Action	REPLACE
Urgency of Action	PRIORITY 3
Purpose of Action	LEVEL 2
Deficiency Photo1	
Violations	Containerization Area No violations recorded.
Deficiency	DAMAGED/DETERIORATED/MISSING SECTIONS
Deficiency Location/Instance	Near Exit 6, Garden Area, Containerization Area
Deficiency Quantity	1,300
Quantity Uom	S.F.
Potential Action	REPLACE
Urgency of Action	PRIORITY 3
Purpose of Action	LEVEL 2

**NYC Department of Education
Building Condition Assessment Survey 2023 - 2024**

Architectural Inspection

Q053

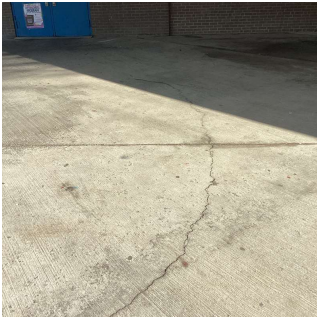
Question	Response
SITE	
PAVING	
Site Sidewalks & Walkways	
Concrete	Inspected
Deficiency Photo1	
	Near Exit 6
Violations	No violations recorded.
Pavers	Does not Exist
DOT Sidewalk	Inspected
Asphalt	Does not Exist
Concrete	Inspected
Condition	4 - Between Fair and Poor
Deficiency	HEAVING
Deficiency Location/Instance	Beach 18th Street
Deficiency Quantity	30
Quantity Uom	S.F.
Potential Action	REPLACE
Urgency of Action	PRIORITY 5
Purpose of Action	LEVEL 6
Deficiency Photo1	
	Beach 18th Street
Violations	No violations recorded.
Deficiency	DAMAGED CURBS
Deficiency Location/Instance	Nameoke Street, Bayport Place, Beach 18th Street
Deficiency Quantity	180
Quantity Uom	L.F.
Potential Action	REPLACE
Urgency of Action	PRIORITY 3
Purpose of Action	LEVEL 2

**NYC Department of Education
Building Condition Assessment Survey 2023 - 2024**

Architectural Inspection

Q053

Question	Response
SITE	
PAVING	
DOT Sidewalk	
Concrete	
Deficiency Photo1	
Violations	Nameoke Street No violations recorded.
Deficiency	DAMAGED/DETERIORATED/MISSING SECTIONS
Deficiency Location/Instance	Nameoke Street, Bayport Place, Beach 18th Street
Deficiency Quantity	1,025
Quantity Uom	S.F.
Potential Action	REPLACE
Urgency of Action	PRIORITY 3
Purpose of Action	LEVEL 2
Deficiency Photo1	
Violations	Nameoke Street No violations recorded.
Pavers	Does not Exist
PLAYGROUNDS	Inspected
Instance on Schoolyard	Inspected
Benches	
Instance on Schoolyard	Does not Exist
Fence	
Instance on Schoolyard	Does not Exist
Pavement	
Instance on Schoolyard	Does not Exist
Play Equipment	
Instance on Schoolyard	Inspected
Condition	2 - Between Good and Fair
Deficiency	No deficiencies recorded
Safety Surfacing	
Instance on Schoolyard	Inspected
Condition	3 - Fair

NYC Department of Education
Building Condition Assessment Survey 2023 - 2024

Architectural Inspection

Q053

Question	Response
SITE	
PLAYGROUNDS	
Safety Surfacing	
Deficiency	DETERIORATED/MISSING
Deficiency Location/Instance	Near Bayport Place Entrance, Near Sliding, Climbing Wall
Deficiency Quantity	100
Quantity Uom	S.F.
Potential Action	REPLACE
Urgency of Action	PRIORITY 3
Purpose of Action	LEVEL 2
Deficiency Photo1	
Violations	Near Sliding No violations recorded.
Deficiency	DETERIORATED/MISSING
Deficiency Location/Instance	Near Bayport Place Entrance, Playground Perimeter
Deficiency Quantity	100
Quantity Uom	S.F.
Potential Action	REPLACE
Urgency of Action	PRIORITY 5
Purpose of Action	LEVEL 6
Deficiency Photo1	
Violations	Near Bayport Place Entrance No violations recorded.
Unpaved Area	
Instance on Schoolyard	Does not Exist
PLAYING SURFACE	
Playing Field	Inspected
Instance on Schoolyard	Inspected
Instance Condition	2 - Between Good and Fair
Deficiency	No deficiencies recorded
Running Track	
Running Track	Does not Exist
RETAINING WALLS	
Are there any Retaining Walls 6' OR higher facing public street/sidewalk?	No

**NYC Department of Education
Building Condition Assessment Survey 2023 - 2024**

Architectural Inspection

Q053

Question	Response
SITE	
RETAINING WALLS	
Condition	3 - Fair
Deficiency	CAST IN PLACE CONCRETE: CRACKS/SPALLING - MAJOR
Deficiency Location/Instance	Containerization Area
Deficiency Quantity	40
Quantity Uom	S.F.
Potential Action	REPLACE
Urgency of Action	PRIORITY 3
Purpose of Action	LEVEL 2
Deficiency Photo1	
Violations	Containerization Area No violations recorded.
SEATING	
	Inspected
Benches	
	Inspected
Concrete	
Condition	5 - Poor
Deficiency	CRACKS/SPALLING - MAJOR
Deficiency Location/Instance	Courtyard
Deficiency Quantity	3
Quantity Uom	EACH
Potential Action	REPLACE
Urgency of Action	PRIORITY 3
Purpose of Action	LEVEL 2
Deficiency Photo1	
Violations	Courtyard No violations recorded.
Metal/Wood/Plastic	
Condition	2 - Between Good and Fair
Deficiency	No deficiencies recorded
Bleachers	
	Does not Exist
SITE WALLS (NOT RETAINING WALLS)	
	Inspected
Condition	2 - Between Good and Fair
Deficiency	CAST IN PLACE CONCRETE: CRACKS/SPALLING - MAJOR

**NYC Department of Education
Building Condition Assessment Survey 2023 - 2024**

Architectural Inspection

Q053

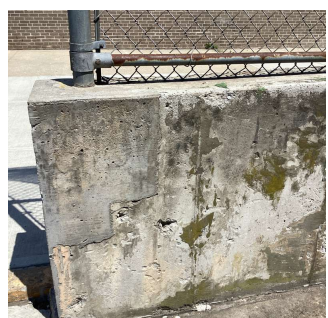
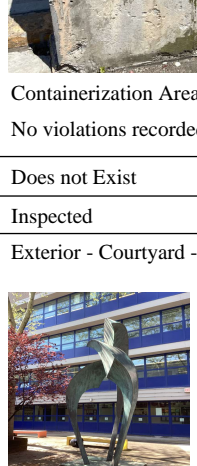
Question	Response
SITE	
SITE WALLS (NOT RETAINING WALLS)	
Deficiency Location/Instance	Office/Storage
Deficiency Quantity	20
Quantity Uom	S.F.
Potential Action	REPLACE
Urgency of Action	PRIORITY 3
Purpose of Action	LEVEL 2
Deficiency Photo1	
	Containerization Area
Violations	No violations recorded.
STAIRS/RAMPS: EXTERIOR	
	Does not Exist
ARTWORK	
Instance	Inspected
Instance Photo	Exterior - Courtyard - 11132
	
	Courtyard
Instance ID	11132
Artwork exist at stated location?	Yes